



# **FRENIC-Lift**

## Starting guide for DCP

3 ph 400 VAC 2.2 – 45 kW  
3 ph 200 VAC 4.0 – 15 kW  
1 ph 200 VAC 2.2 – 4.0 kW

<b>Version</b>	<b>Changes applied</b>	<b>Date</b>	<b>Written</b>	<b>Checked</b>	<b>Approved</b>
1.0.0	First version	14.11.2022	J. Alonso	C. Arjona C. Wolf	J. Català

## CONTENTS

0. Introduction .....	4
1. Connections .....	4
1.1 RS485 bus terminals .....	4
1.2 Shield connection .....	5
1.3 Terminal resistor.....	6
2. Remote display .....	6
2.1 Remote display keys .....	6
2.2 Remote display menus .....	7
3. Basic setting.....	10
3.1 DCP bus setting .....	10
3.2 Lift / motor basic setting.....	10
3.3 Lift speeds.....	11
4. Start-up .....	12
5. Lift speed profile settings.....	13
5.1 DCP 3 (Lift controller without absolute sensor system).....	13
5.2 DCP 4 (Lift controller with absolute sensor system).....	14
6. Signals timing diagram in DCP .....	15
6.1 DCP 3 (Speed mode) .....	15
6.2 DCP 4 (Remaining distance mode) .....	16
7. Travel optimization (Remaining distance mode) .....	17

## 0. Introduction

Thank you very much for choosing FRENIC-Lift (LM2) inverter series.

This starting guide includes the basic information to operate FRENIC-Lift (LM2) via Drive Control Position (DCP). To do so a lift controller based on DCP is necessary. This starting guide is written from end users point of view (not developers).

FRENIC-Lift (LM2) inverter series has two models: LM2A and LM2C. Supported functions for each model is listed below:

- LM2A:
  - o DCPComChan
  - o DCP 3
  - o DCP 4
  
- LM2C:
  - o DCPComChan
  - o DCP 3

**Note** This starting guide is based on firmware version 1000 or later. For other software versions, please contact with Fuji Electric technical department.

Firmware version (ROM) can be monitored on TP-E1U in 5\_14 and on TP-A1-LM2 in PRG > 3 > 4

For extended information about the product and its use, refer to below mentioned documents:

- FRENIC-Lift LM2A series Reference Manual INR-SI47-1909\_-E (RM).
- FRENIC-Lift LM2A series Instruction Manual INR-SI47-1894\_-E (IM).
- FRENIC-Lift LM2C series Instruction Manual INR-SI47-2224\_-E (IM).
- FRENIC-Lift LM2A series Starting guide SG\_LM2A\_EN\_x.x.x (SG).
- FRENIC-Lift LM2C series Starting guide SG\_LM2C\_EN\_x.x.x (SG).

### ⚠ CAUTION

DCP communications (3 or 4) is not compatible with CANopen 417. Therefore Remote display of DCP cannot be used at same time than CANopen 417 virtual console.

## 1. Connections

### 1.1 RS485 bus terminals

FRENIC-Lift has two RS485 ports built-in. Port 1 is placed in RJ-45 connector (figure 1.1), Port 2 in TERM5 terminals (figure 1.2). Table 1.1 shows the cross-reference between DCP signals, terminals and ports.

CAN bus terminal is placed in Terminals-PCB and it is called TERM1. Terminal is shown in figure 1.1; the meaning of each terminal is described in table 1.1.

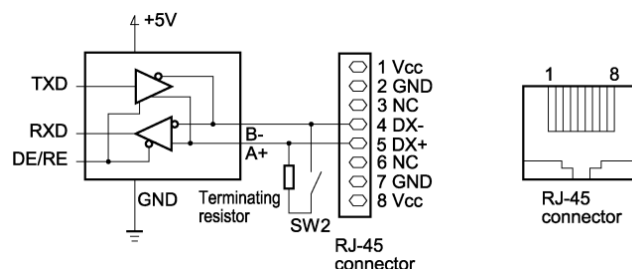

Figure 1.1. DCP Port 1 (RS485 1)

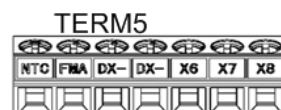

Figure 1.2. DCP Port 2 (RS485 2)

Table 1.1. DCP bus terminal symbols description

Controller	Connection in Port 1	Connection in Port 2	Comments
DCP A	Pin 5	DX+	
DCP B	Pin 4	DX-	
Ground	Pin 2 or Pin 7	11 (TERM 3)	This terminal might be connected in case of big electric noise disturbance.

**Note** To prevent malfunction against the noise and ensure reliability please use twisted and shielded cables for DCP bus.

Figure 1.3 shows a basic diagram of a DCP system where “drive controller” is the inverter. Absolute encoder (in shaft) appears only in the systems where DCP 4 is implanted.

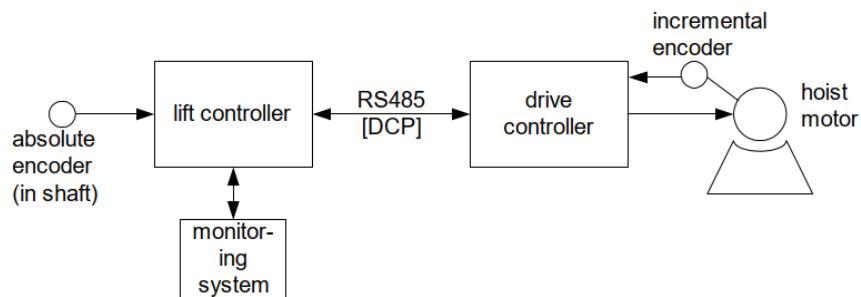

Figure 1.3. Connection via DCP

## 1.2 Shield connection

As explained before, it is recommended to use shielded cables. FRENIC-Lift has specific metal plates to connect the shield of RS485 bus wires. The position of the metal plate depends on the inverter capacity. An example of metal plate position and recommended connection method is shown in figure 1.4.

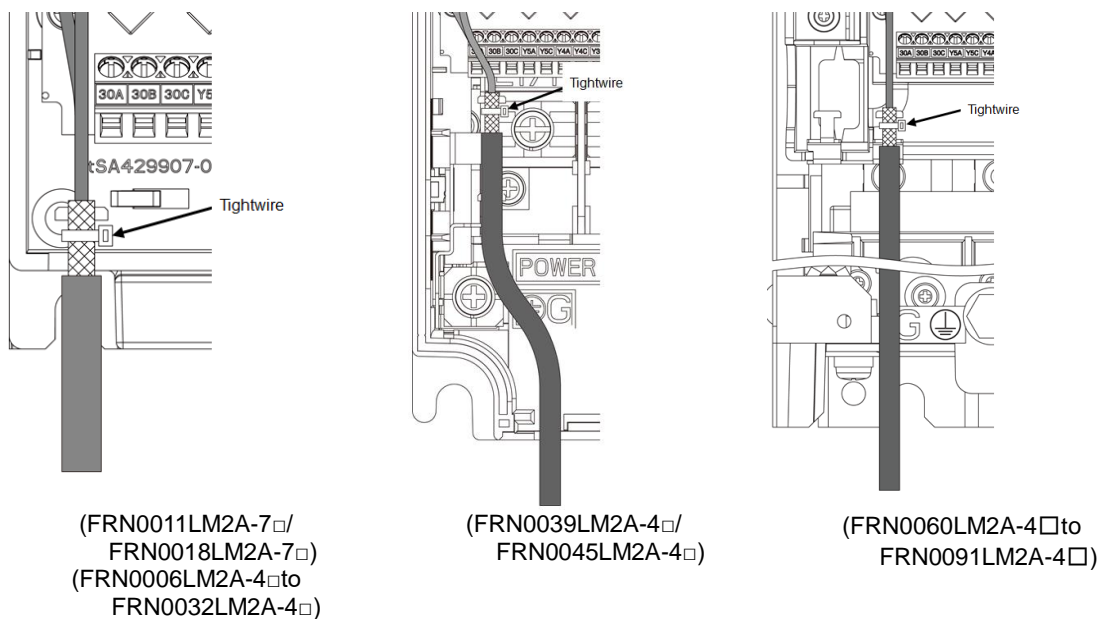

Figure 1.4. Metal plate for shield connection position

### 1.3 Terminal resistor

RS485 bus are provided with a terminal resistor. Terminal resistors are connected/disconnected by switches placed in Control PCB board shown in figure 1.5.

Terminal resistor for Port 1 is in SW2 and terminal resistor for Port 2 is in SW3.

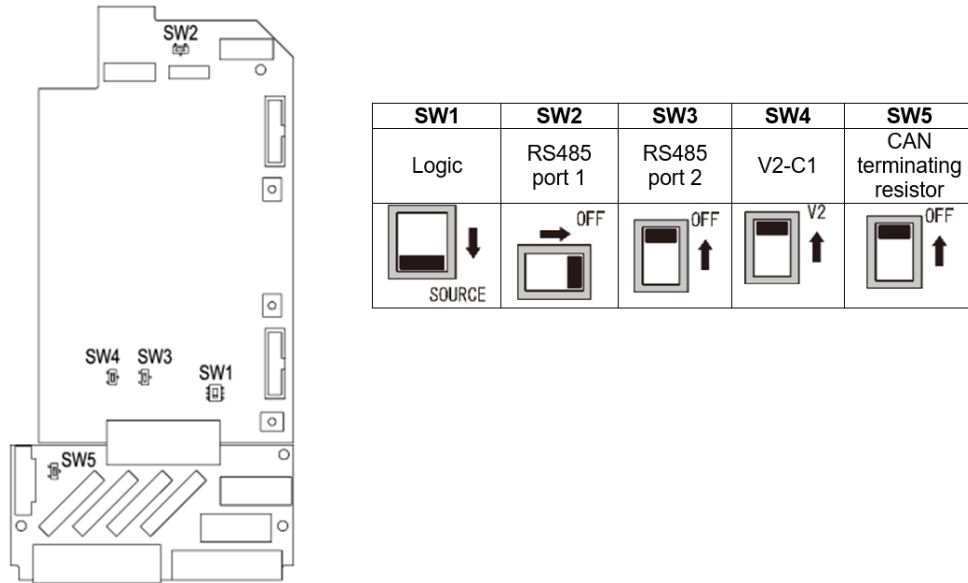

Figure 1.5. Switches position and its meaning in Control PCB.

By default, the terminal resistor is disabled (OFF position). In case of DCP please switch them ON depending on the Port used.

## 2. Remote display

FRENIC-Lift has implemented the Remote display function; therefore it can be operated by means of lift controller keypad. Data can be monitored by lift controller screen as well. The way to access remote display and the buttons functionality differs from each lift controller manufacturer. For additional information how to access remote display, please check with lift control manufacturer.

### 2.1 Remote display keys

In table 2.1, the main function for each key on the controller keypad is described. The sign shown in the key column might differ from the controller's keypad.

Table 2.1. Remote display keys description

Key	Role / behavior
	Move to the next group which is defined in current page. If the next group is not defined, nothing happens. In case of "Function setting group" or "F-code + Monitor", move to corresponding function setting. Request writing the value to the function code, then move to "waiting" page. Decide to execute or not.
	Move to previous page in current group. In case of the first page, move to the last page. Increment setting value toward maximum value. Move cursor to "yes".
	Move to next page in current group. In case of the last page, move to the first page. Decrement setting value toward minimum value. Move cursor to "no".
or	Move cursor to the right. In case the cursor is located at most right, move cursor to most left.
or	Move to the previous group which is defined in current page. If the previous page is not defined, nothing happens. Back to the original page without storing the function code data.

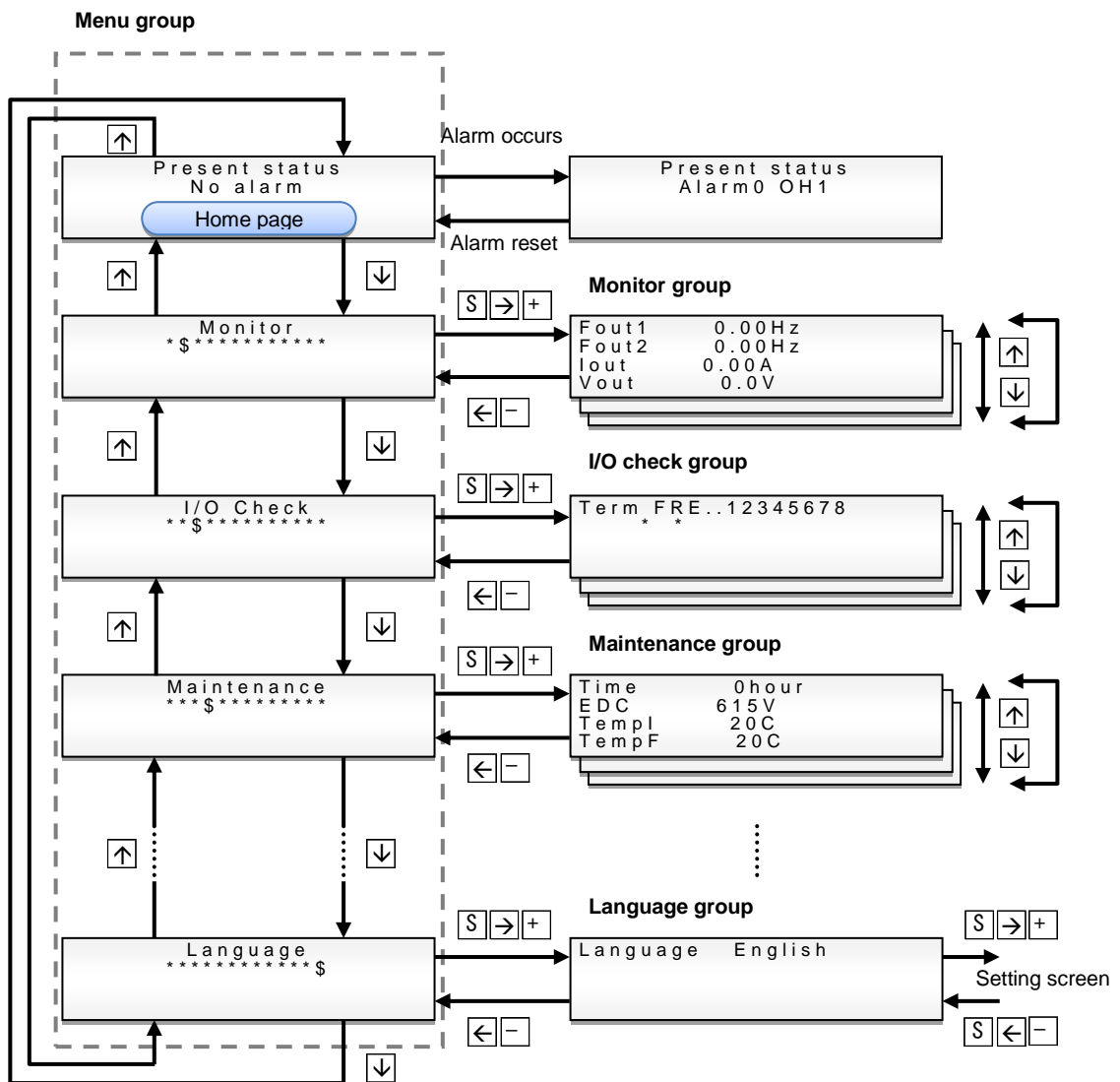

Figure 2.1. Flow diagram to move across Remote display and its menus.

Figure 2.2 shows how to modify the setting of parameter F01 using Remote display keys. The setting of parameter F01 is modified from 1 (default setting) to 2. Parameter is modified as soon as the screen showing the message “Writing completed” appears.

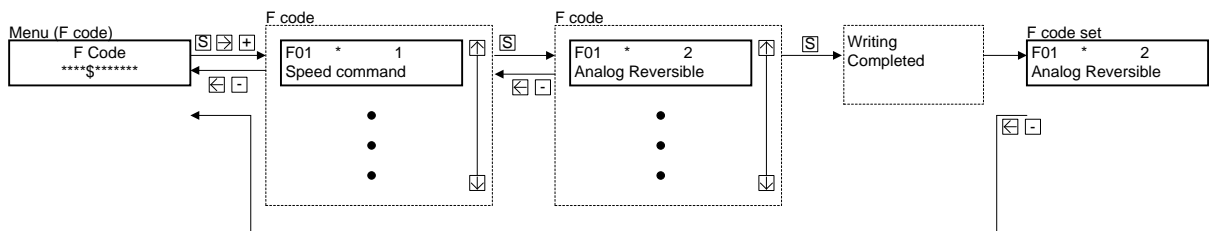

Figure 2.2. Inverter parameter modification example.

## 2.2 Remote display menus

Remote display is organized by different menus; in each menu different information can be monitored or modified. The name of the menus is listed below:

- Monitor
- I/O check
- Maintenance
- Alarm
- Function codes
- TrqBias
- Language setting

Function codes are grouped by families. Families are F, E, C, P, H, y, L, L1, L2 and L3.

Two types of languages can be selected: English and German.

Figures below show which information can be monitored or modified in each menu.

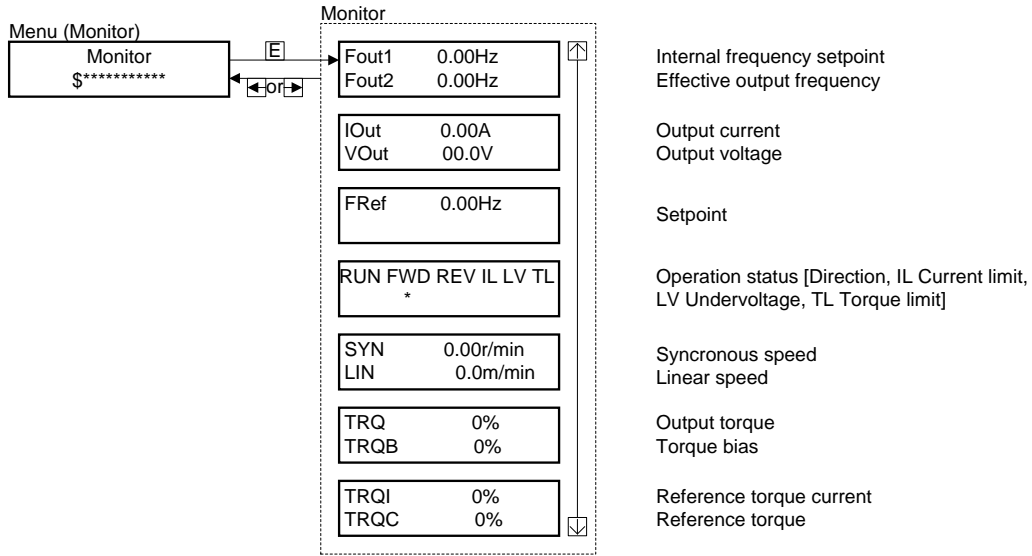

Figure 2.3. Monitor menu

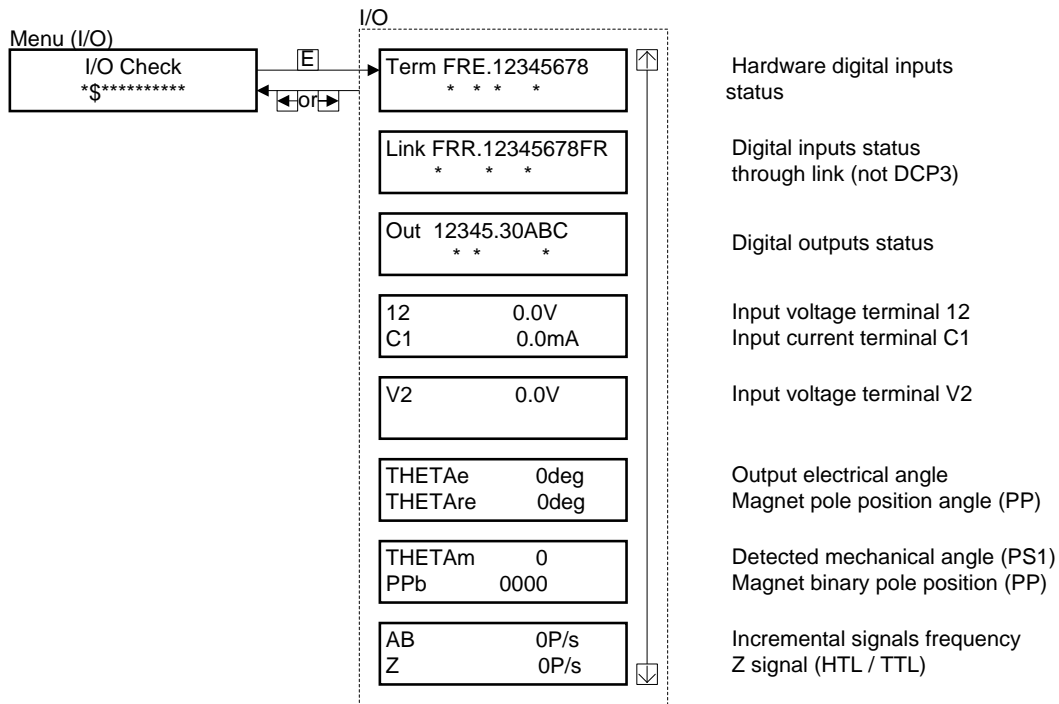

Figure 2.4. I/O check menu



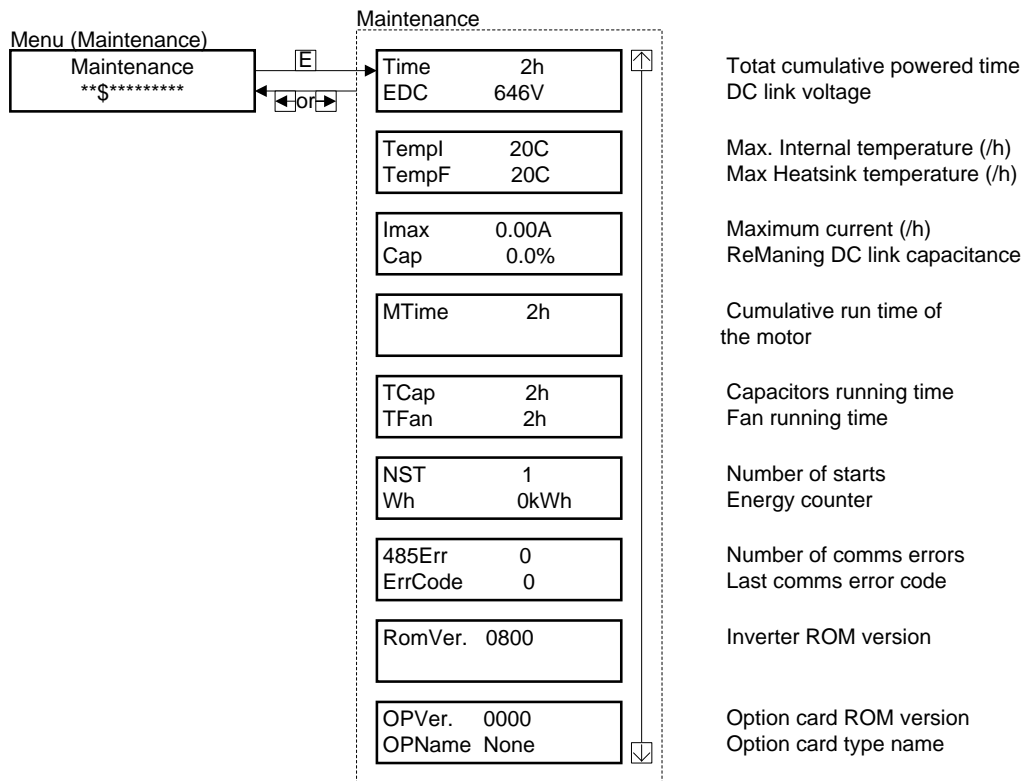

Figure 2.5. Maintenance menu

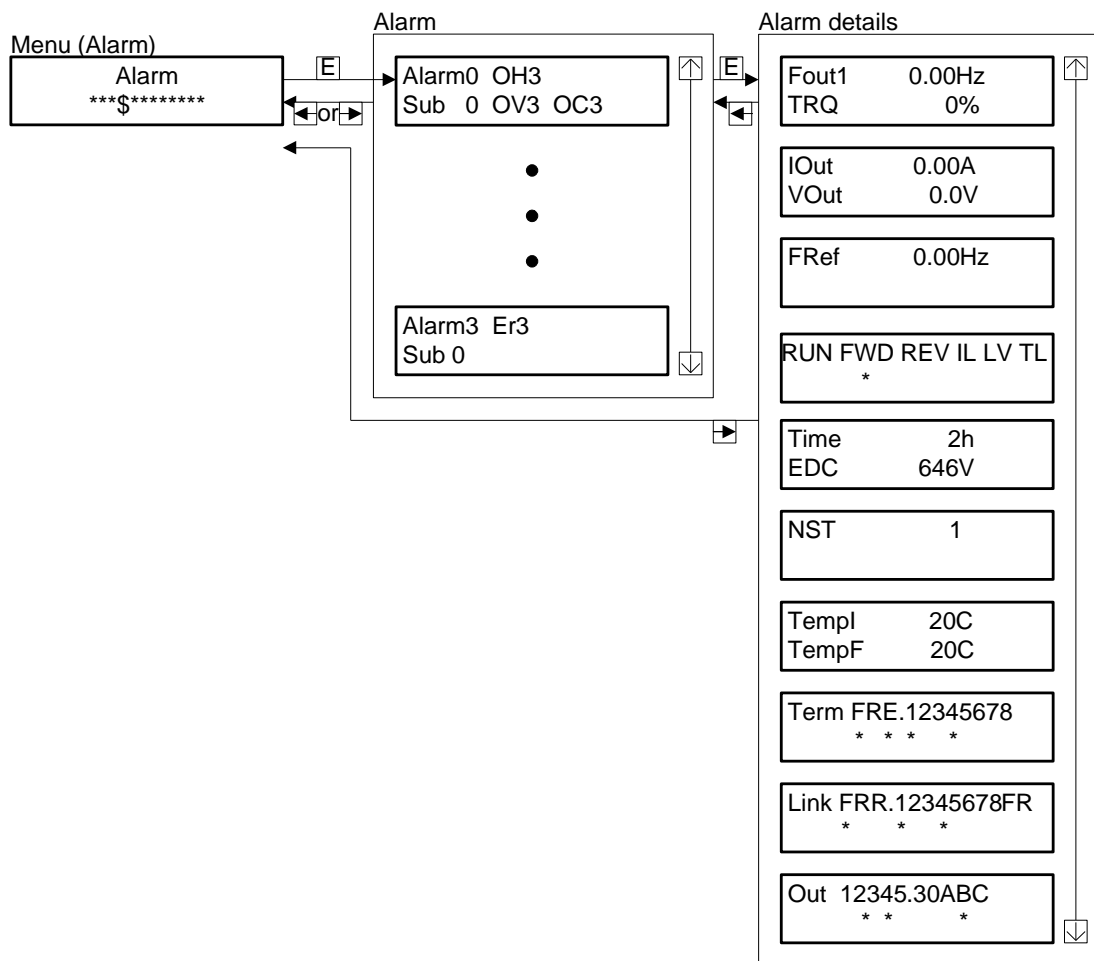

Figure 2.6. Alarm menu

### 3. Basic setting

#### 3.1 DCP bus setting

To enable the internal DCP interface it is necessary to setup some parameters. Basic setting is shown in table 3.1.

Table 3.1. Basic setting to enable DCP control

Function code	Description	Setting	Comments
y10	RS485 Communication 1 (protocol selection)	5: DCP 3 6: DCP 4	Both ports cannot be used at same time with DCP functionality.
y20	RS485 Communication 2 (protocol selection)	5: DCP 3 6: DCP 4	

By setting y10=5 or 6 (y20) the inverter automatically sets internally baud rate=38.400 bps, Data bits=8, Parity=none and Stop bits=1. In other words, the other y parameters will have no effect.

To enable all settings related to basic DCP communication it is necessary to reboot the inverter; it is recommended to reboot also the Lift Controller. Power down until keypad and charging LED are OFF, then power ON again. After rebooting, the controller will start the communication with the inverter.

When boot up sequence is finished, make sure lift controller does not display any error related to inverter (drive unit). In affirmative case, please check with lift controller manufacturer.

#### 3.2 Lift / motor basic setting

In DCP 4, in other words when we refer to Position control, it is very important to match lift speed and motor parameters. Table 3.2 shows all relevant parameters related to lift speed and motor.

Table 3.2. Lift / Motor basic setting

Function code	Description	Setting	Comments
C21	Speed command unit	0: rpm	Inverter will speak always in mm/s with the lift controller. The setting of this parameter affects only in the speed units set on F04. Do not change default setting of this parameter if not needed.
P01	Motor (N° of poles)	-	Refer to LM2A Starting guide for this setting.
F03	Rated speed (maximum speed)	-	Motor speed to reach lift rated speed (L31).
L31	Elevator parameter (speed)	-	Lift speed at motor speed (F03).
F04	Base speed	-	Refer to LM2A Starting guide for this setting.
F05	Rated voltage	-	
P02	Motor (rated capacity)	-	
P03	Motor (rated current)	-	

The programming order of these parameters is very critical. In other words, if the order shown in the table is not followed, parameters which are already set can change its value. Please program C21, P01, F03 and L31 in this order before than the rest of parameters.

Most of the parameters shown in table 3.2 are important for a proper motor control as well; make sure to set them properly and to perform auto and/or pole tuning. In case of doubt, please refer to LM2A Starting guide.

**Note** Sometimes, the motor rated characteristics (rpm, pulley, sheave, gearbox, etc.) does not match with the speed lift has been designed for. In other words, when motor turns at rated speed, can be that the lift moves faster than expected. Use below formula to determine which are the motor rpm for the lift characteristics.

$$n_{rated} = \frac{19,1 \times v \times r}{D \times i}$$

Where:

v: rated speed in m/s

r: Cabin suspension (1 for 1:1, 2 for 2:1, 4 for 4:1,...)

D: Pulley diameter in m

i : Gear ratio (in case of gearless = 1)

n<sub>rated</sub>: Motor rated speed (in rpm) at lift maximum speed

**Example1: Lift with Permanent Magnets Synchronous Motor**

Motor characteristics:

Motor rated speed=112,4 rpm  
 Motor rated voltage=360 VAC  
 Motor poles= 20  
 Motor pulley=340 mm  
 Motor gearbox= Gearless

Lift characteristics:

Rated speed= 1,00 m/s  
 Suspension= 1:1

$$n_{rated}=(19,1*1)/(0,340*1)=56,17 \text{ rpm}$$

Therefore, inverter setting will be:

- C21=0
- P01=20
- F03=56,17 rpm
- L31=1000 mm/s
- F04=112,4 rpm
- F05=360 VAC
- Etc.

**Example2: Lift with Geared Induction Motor**

Motor characteristics:

Motor rated speed=1413 rpm  
 Motor rated voltage=380 VAC  
 Motor poles= 4  
 Motor pulley=500 mm  
 Motor gearbox= 2/74

Lift characteristics:

Rated speed= 1,00 m/s  
 Suspension= 1:1

$$n_{rated}=(19,1*1*71)/(0,500*2)=1413 \text{ rpm}$$

Therefore, inverter setting will be:

- C21=0
- P01=4
- F03=1413 rpm
- L31=1000 mm/s
- F04=1500 rpm
- F05=380 VAC
- Etc.

### 3.3 Lift speeds

Lift speeds are programed in the C parameters. Table 3.3 shows a cross-reference between DCP specifications speed and C parameters. Please note that depending on the mode selected (DCP 4 or 3) some speeds are available or not.

Table 3.3. Cross-reference between DCP speeds and C parameters

DCP 3 Notation	DCP 4 Notation	Parameter	Description
V0	V0	C07	Crawl
VN	VN'	C05	Relevelling
VF	-	C04	Fast start (zero speed)
V1	-	C08	Intermediate3
VI	VI	C06	Inspection
V2	-	C09	Intermediate2
V3	V3'	C10	Intermediate1
V4	V4'	C11	Fast

 Please note that these parameters have a default setting. Make sure the setting matches with your lift installation, and if not, modify them accordingly. In case the speeds are set to zero, the lift will not move.

## 4. Start-up

It is recommended to follow the start-up procedures described on FRENIC-Lift LM2A Starting guide. The start-up procedure is different depending on the motor type (Induction Motor open or closed loop and Permanent Magnets Synchronous Motor). Start-up procedure can be either done with FRENIC-Lift keypads (TP-A1-LM2 or TP-E1U) or with Remote display (described on Chapter 2 of this manual).

<b>⚠ CAUTION</b>
In case that your lift controller controls the opening of the brake, make sure that it is disabled during Pole tuning (for PMS motors) and Auto tuning (for Induction motors). If brake opens, the result of the tuning might be not correct, additionally the lift car might move without control.

Make sure as well that the travel cancellation due to no movement function is disabled. If your lift controller has this function activated, due to the non-movement of the lift car during the tuning, it will stop the tuning process. In such case inverter will trip Er7 (SUB=7 or 24).

As described on the Starting guide, first movement should be carried out in inspection (auxiliary control mode). Check if the driving direction matches with the commanded direction. If it does not match, change the bits 4 on the parameter L99.

Table 4.1. Parameter L99 description

Function code	Description	Setting range
L99(bit4)	Control switch (Rise direction definition for DCP)	Bit4=0 (xxx0 xxxx) -> FWD Bit4=1 (xxx1 xxxx) -> REV

At this point, it is important to make sure that the speed monitored in inverter keypad and real lift speed (Speed shown by shaft encoder or controller) is the same. If this is not the case, check the setting on the parameter F03 (maximum speed) and L31 (Elevator speed) as described in Chapter 3.2.

In case of TP-A1-LM2, lift speed is shown on below screen (PRG>3>1 [1/8]):

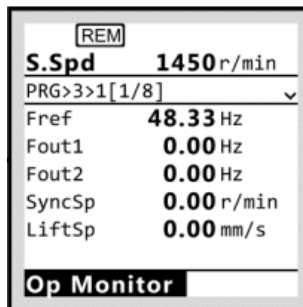

In case of TP-E1U, you can monitor lift speed in below parameters:

- 3\_08: Motor speed / Detected speed (rpm)
- 3\_33: Lift speed (mm/s)

Additionally, in parameter W209 PRG > 6 > 3 you can monitor Command byte and Status byte from DCP frame. Table 4.2 shows W209 bit description.

Table 4.1. W209 parameter bit description

Command byte								Status byte							
B7	B6	B5	B4	B3	B2	B1	B0	S7	S6	S5	S4	S3	S2	S1	S0
Error in last reply message	Distance (0:actual, 1:desired)	Speed change	Travel direction (0:Up, 1:Down)	Speed mode	V0 off switch	Travel command (only in DCP3)	Drive controller enable	Error in last reply message	Open mechanical brake (BRKS)	Desired distance / speed acceptance	Speed detection. 0: v>=0,3 m/s, 1: v<0,3 m/s (FDT)	General fault active	Advance warning active	Travel active	Drive controller ready

## 5. Lift speed profile settings

The speeds used in DCP, either 3 or 4, are defined in table 3.3. Ramps and s-curves will be defined by the speed I'm coming from to the speed I'm going to (as described in the Starting guide). In the next sub chapters, you can find most used speed profiles depending on the mode.

### 5.1 DCP 3 (Lift controller without absolute sensor system)

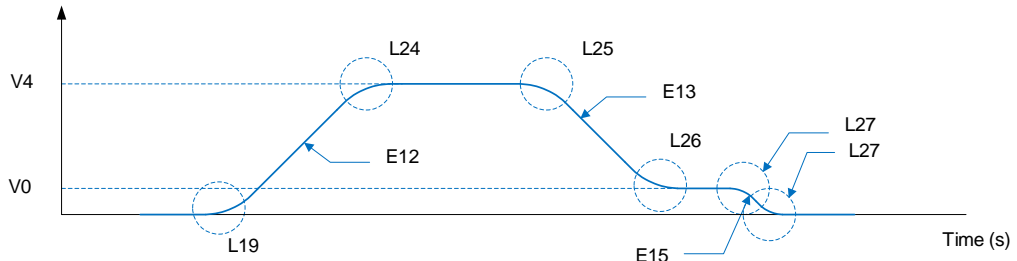

Figure 5.1. V4 long travel

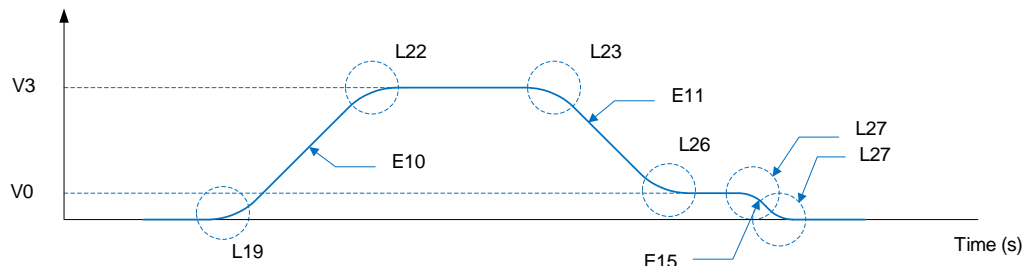

Figure 5.2. V3 long travel

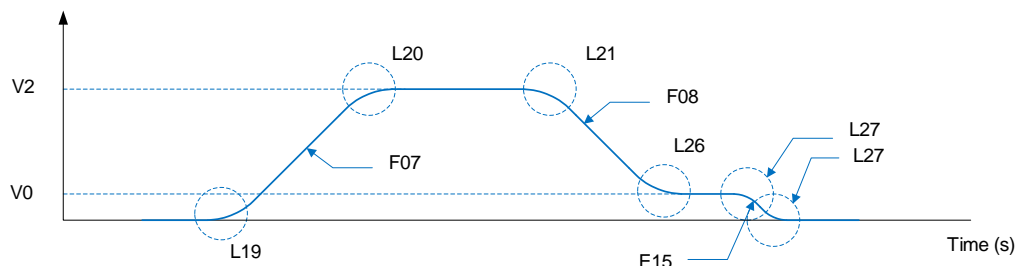

Figure 5.3. V2 long travel

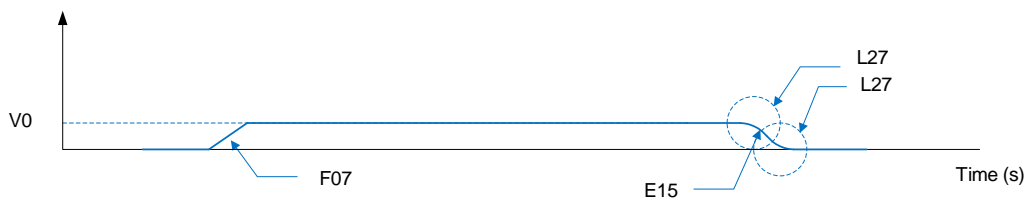

Figure 5.4. Crawl travel

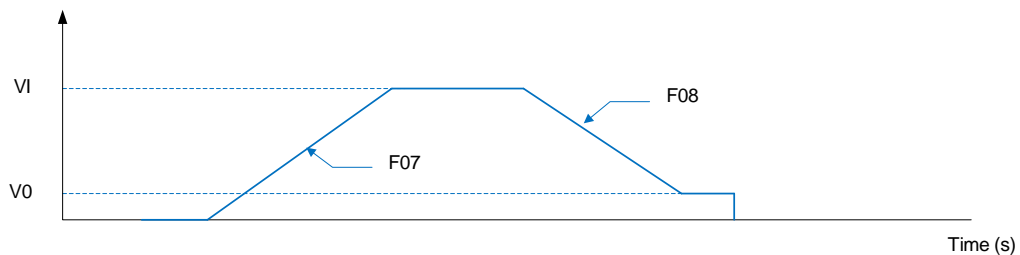

Figure 5.5. Inspection travel using VI

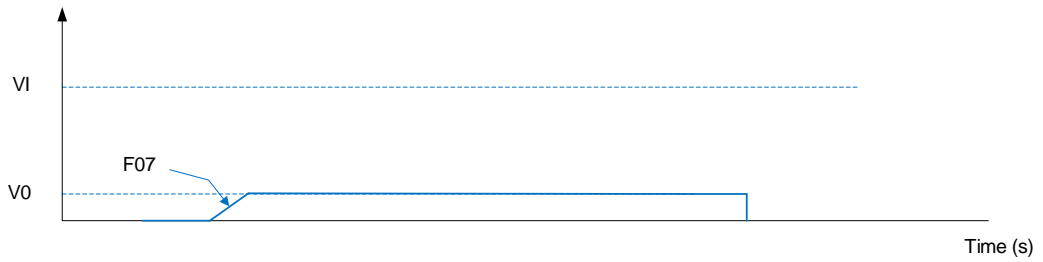

Figure 5.6. Inspection travel using V0

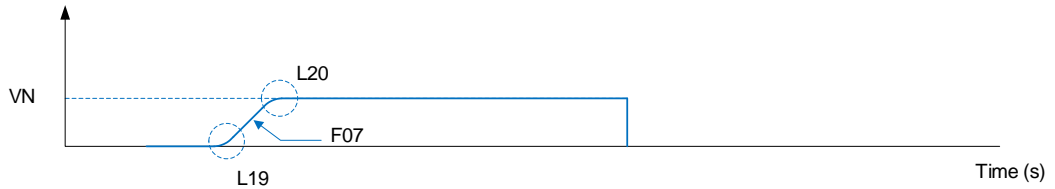

Figure 5.7. Relevelling travel without electric stop

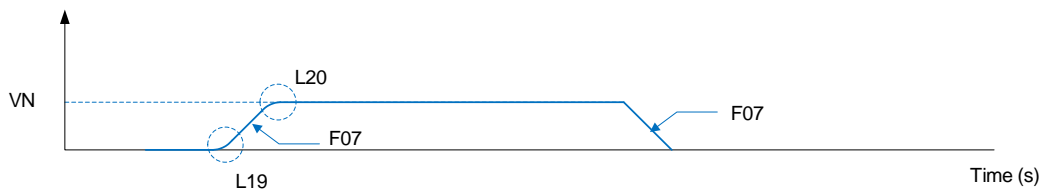

Figure 5.8. Relevelling travel with electric stop

## 5.2 DCP 4 (Lift controller with absolute sensor system)

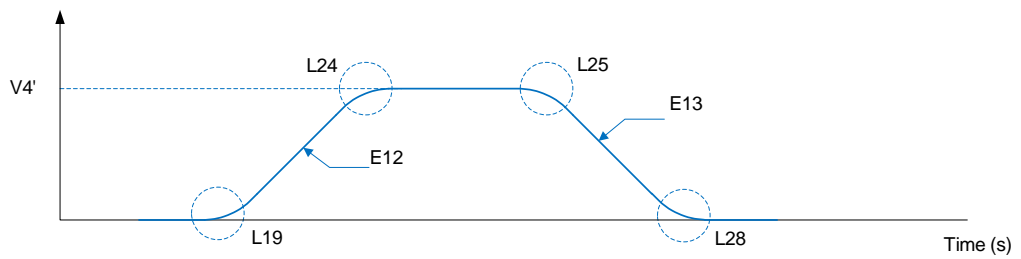

Figure 5.9. V4' long travel

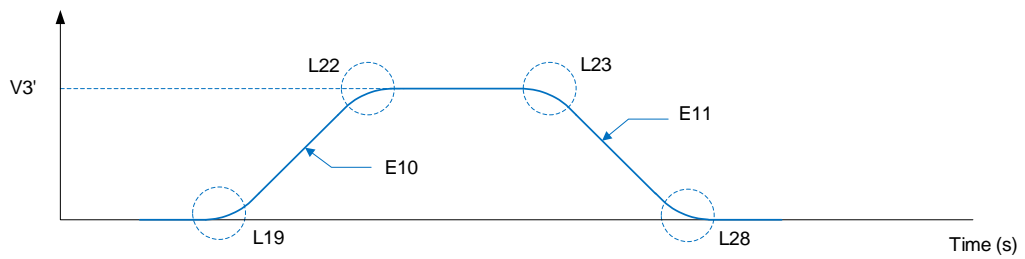

Figure 5.10. V3' long travel

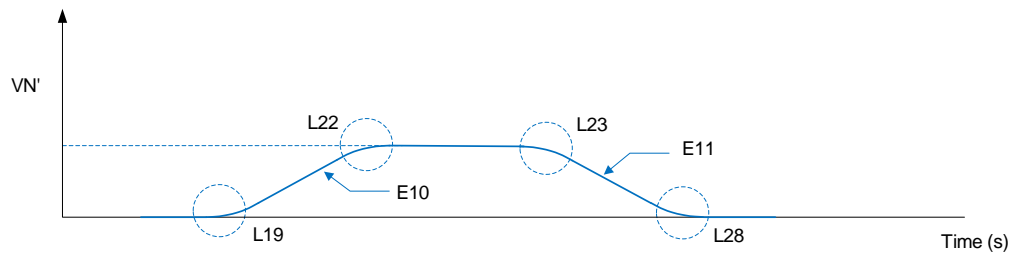

Figure 5.11. VN' Relevelling travel

## 6. Signals timing diagram in DCP

In the following chapter, we will explain the sequence of signals coming from Command byte, its answer from Status byte and the effect on lift travel speed. Additionally you will see a cross-reference with the inverter functions. We divide the chapter between DCP 3 (Speed mode) and DCP 4 (Remaining distance control).

### 6.1 DCP 3 (Speed mode)

Figure 6.1 shows a complete timing diagram and signals sequence in case of DCP 3 lift movement. The movement analysed uses V4 long travel speed. On the first part of the graphic (top), we see speed profile, after speed signals in command and status byte. Finally, the cross-reference between command and status byte signals and inverter signals.

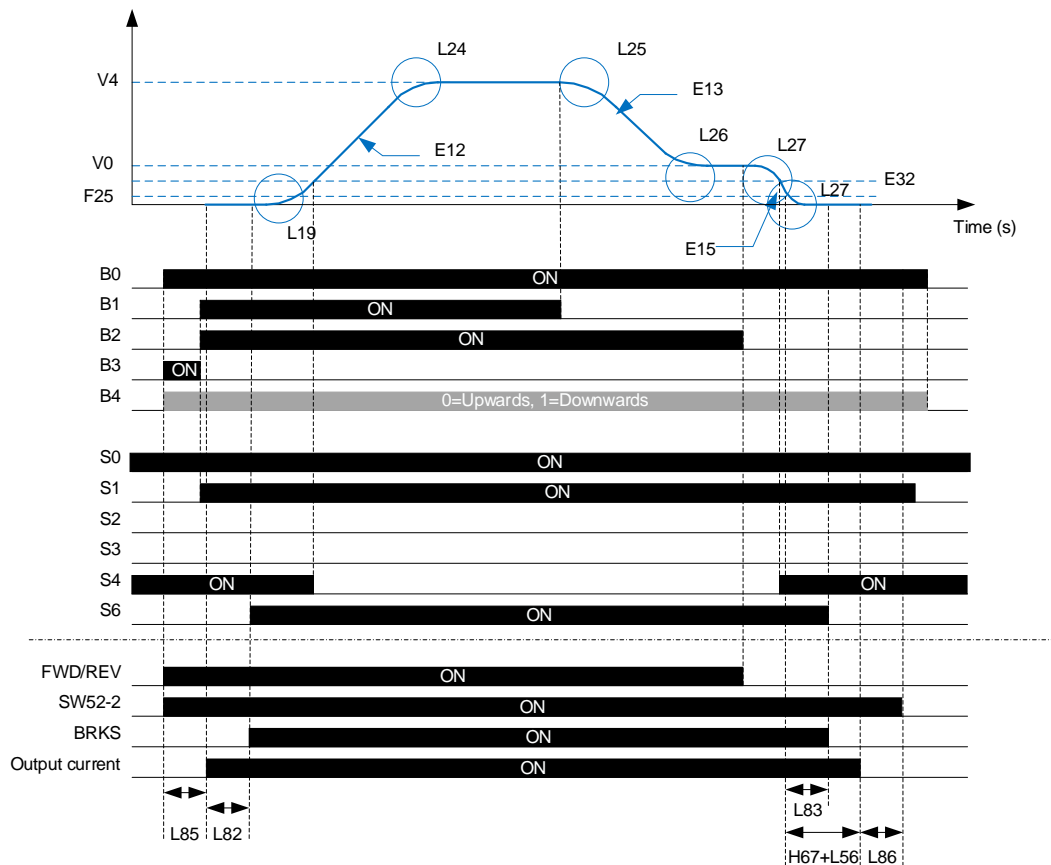

Figure 6.1. DCP 3 time and signals sequence diagram.

Sequence description:

#### Start:

From the inverter point of view, if all is correct (input voltage existent, no alarm, etc.); we have bit S0 that means inverter ready for a lift movement.

At starting, lift controller activates command byte bits 0, 3 and 4 (Drive enable, speed mode and direction). This generates that inverter activates internally FWD or REV command (Up or down) and consequently it activates the output to close the main contactors (SW52-2).

Then command byte B3 goes to zero and B1 and B2 to one (Travel command for DCP 3 and v0 off switch OFF). In parallel, the inverter will set S1 bit to one to show a travel has started (when L85 time has elapsed) and brake will open (when L82 time has elapsed).

The start sequence finish with the acceleration phase (s-curves and ramp). The parameters to adjust acceleration ramp and s-curves differs depending on the selected speed or DCP 3 and 4. For additional information, refer to Chapter 5.

#### Stop:

When the lift controller sets to zero B2 bit we can say stopping phase starts. At this point, the inverter decelerates the motor from V0 (C07) speed to zero speed to reach target floor.

During the deceleration phase, the stopping speed level (F25) is reached. This speed level initiates the timers to close the brake (L83) and to hold zero speed at stop (H67).

After zero speed holding time and demagnetization ramp times are finished (H67+L56) the delay time to open main contactors starts (L86).

Trip is finished when controller sets to zero B0 bit on command byte.

## 6.2 DCP 4 (Remaining distance mode)

Figure 6.2 shows a complete timing diagram and signals sequence in case of DCP 4 lift movement. The movement analysed uses V4' as maximum speed. On the first part of the graphic (top), we see speed profile and Remaining distance, after speed signals in command and status byte. Finally, the cross-reference between command and status byte signals and inverter signals.

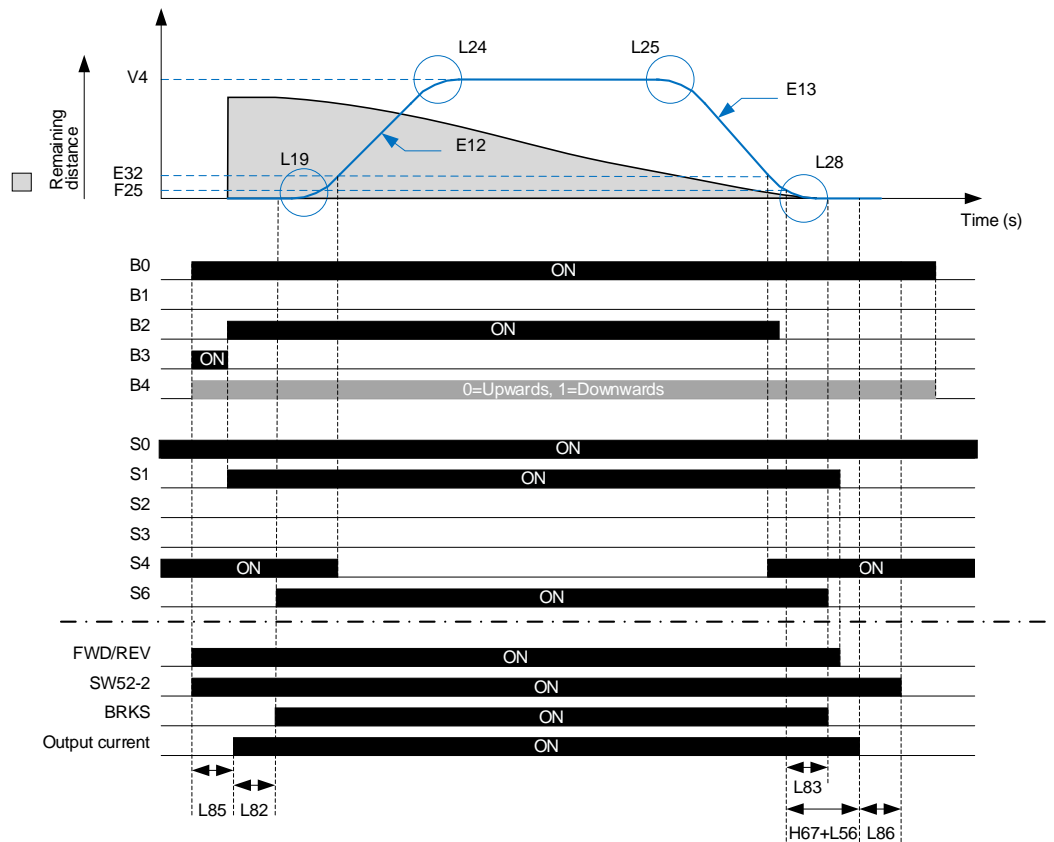

Figure 6.2. DCP 4 time and signals sequence diagram.

Sequence description:

### Start:

From the inverter point of view, if all is correct (input voltage existent, no alarm, etc.); we have bit S0 that means inverter ready for a lift movement.

At starting, lift controller activates command byte bits 0, 3 and 4 (Drive enable, speed mode (DCP 3) and direction). This generates that inverter activates internally FWD or REV command (Up or down) and consequently it activates the output to close the main contactors (SW52-2).

Then command byte B3 goes to zero and B2 to one (v0 off switch OFF). At same time, lift controller will update Remaining distance, which shows how far the lift from the target floor is. In parallel, the inverter will set S1 bit to one to show a travel has started (when L85 time has elapsed) and brake will open (when L82 time has elapsed).

The start sequence finish with the acceleration phase (s-curves and ramp). The parameters to adjust acceleration ramp and s-curves differs depending on the selected speed or DCP 3 and 4. For additional information, refer to Chapter 5.

### Stop:

The inverter will start to decelerate the motor to zero speed (and target floor) when Remaining distance and Deceleration distance are equal, at this point we can say stopping phase starts.

During the deceleration phase, the stopping speed level (F25) is reached. This speed level initiates the timers to close the brake (L83) and to hold zero speed at stop (H67).

After zero speed holding time and demagnetization ramp times are finished (H67+L56) the delay time to open main contactors starts (L86).

Trip is finished when controller sets to zero B0 bit on command byte.



## 7. Travel optimization (Remaining distance mode)

There are different parameters to optimize the travel in Remaining distance mode; these parameters are implemented to get the best stopping accuracy.

The parameters are listed in table 7.1.

Table 7.1. Parameters related to stop accuracy in position mode

Function code	Description	Default setting
L352	Early deceleration distance	45 mm
L353	Early deceleration minimum speed	0.0%

L352 and L353 are parameters implemented in order to compensate the communications delay, which may deal with a wrong stopping. Figure 8.1 shows the effect of L352 and L353 due to early deceleration distance.

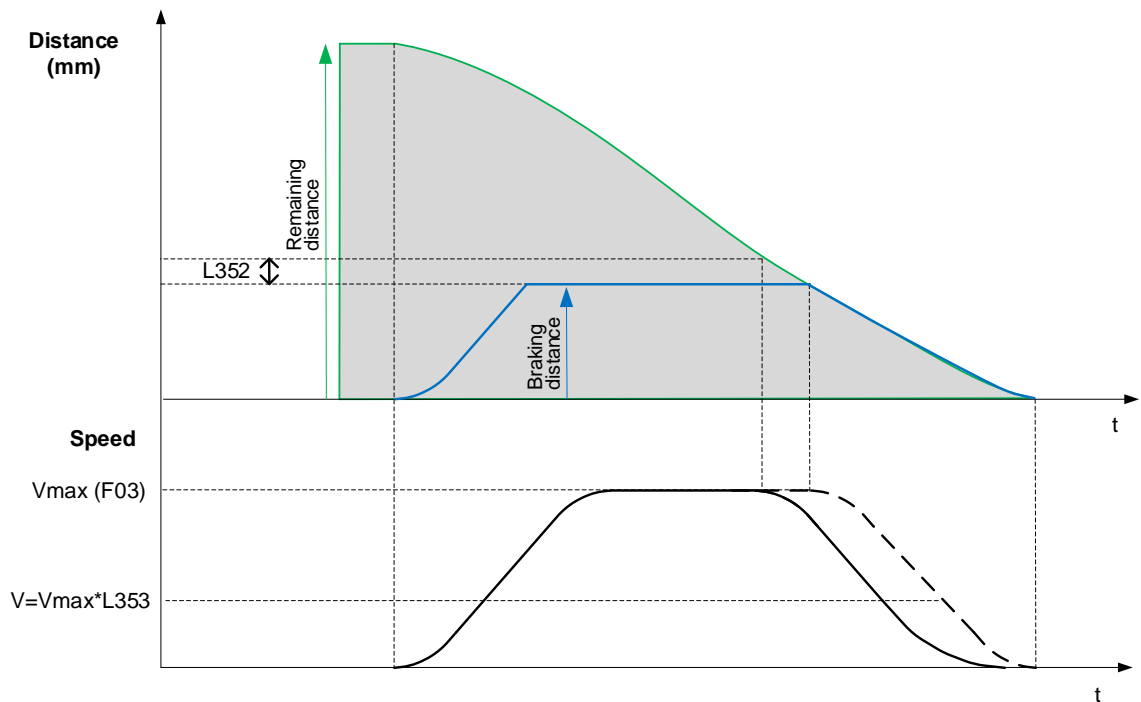

Figure 7.1. Early deceleration distance to compensate communications delay.

As the lift speed has a very important role as well on communication delays and positioning, L352 default setting might be not correct for any lift speed. In other words, depending on lift speed, due to L352 default setting lift behaviour might be erratic. You can detect erratic behaviour because lift stops in a random floor before target floor. L352 default setting is based on a lift with 1000 mm/s rated speed and with certain communication delay. If your lift has lower rated speed or there is no communication delay, most probably you will have to reduce L352 value as well.

L353 specifies from which speed the early deceleration distance is going to be applied. As default setting is 0.0 %, compensation will be applied for any speed.

## CONTACT INFORMATION

Fuji Electric Europe Headquarters

**Fuji Electric Europe GmbH**

Goethering 58  
63067 Offenbach am Main  
Germany  
Tel.: +49 69 669029 0  
Fax: +49 69 669029 58  
info.inverter@fujielectric-europe.com  
technical.inverter@fujielectric-europe.com  
www.fujielectric-europe.com

Swiss Branch

**Fuji Electric Europe GmbH, Swiss Branch**

Rietlistrasse 5  
9403 Goldach  
Tel.: +41 71 858 29 49  
info.swiss@fujielectric-europe.com  
www.fujielectric-europe.com

Spanish Branch

**Fuji Electric Europe GmbH, Sucursal en España**

Carrer dels paletes 8, Edifici B, Primera Planta B  
Parc Tecnològic del Vallès  
08290 Cerdanyola (Barcelona)  
Tel.: +34 935 824 333  
Fax: +34 935 824 344  
info.spain@fujielectric-europe.com  
www.fujielectric-europe.com

French Branch

**Fuji Electric Europe GmbH, French branch**

265 Rue Denis Papin  
38090 Villefontaine  
Tel.: +33 4 74 90 91 24  
Fax: +33 4 74 90 91 75  
info.france@fujielectric-europe.com  
www.fujielectric-europe.com

Italian Branch

**Fuji Electric Europe GmbH, Filiale Italiana**

Via Rizzotto 46  
41126 Modena (MO)  
Tel.: +39 059 4734 266  
Fax: +39 059 4734 294  
info.italy@fujielectric-europe.com  
www.fujielectric-europe.com

UK Branch

**Fuji Electric Europe GmbH, UK Branch**

Bedford i-Lab, Stannard Way, Priory Business Park,  
MK44 3RZ Bedford  
Tel.: +44 1234 834 768  
info.uk@fujielectric-europe.com  
www.fujielectric-europe.com

Subject to change without prior notice