



OPC-LM1-IL

Option Card for Encoder of
Line Driver Output

CAUTION

- Deliver this instruction manual without fail to those who actually operate the equipment.
- Read this operation manual and understand the description before installing, connecting (wiring), operating or performing maintenance and inspection of the option.
- Keep this instruction manual in a safe place until the option is discarded.
- The product is subject to change without prior notice.

Preface

Thank you for purchasing our OPC-LM1-IL inverter option card. Before using the option card, read this manual carefully to understand how to use the option card correctly. Improper handling blocks correct operation or causes a short life or breakdown. This manual does not describe how to use the inverter. Refer to the FRENIC-Lift Instruction Manual for details about the inverter. Keep this manual on hand for reference when using the option card.

Safely Precautions

Note the following items when using the option card. Improper use may result in unexpected failure, electric shock, or possible injury.

(1) Application

WARNING

- This product must not be used for any lifesupport system or other purpose directly related to human safety.
- Although this product is manufactured under strict quality control, be sure to install appropriate safety devices for applications where drive failure could result in serious accident or material loss.
An accident could occur.

(2) Installation and Wiring

WARNING

- Wait at least five minutes after turning off the power before installing or wiring the option card. Use a multimeter or similar instrument to check the voltage before performing installation or wiring. (Check whether the charge lamp goes off.), **otherwise electric shock may occur.**
- Discharge static electricity from your body before handling the option card. Never touch the option card with wet hands, **otherwise accident or electric shock may occur.**
- No foreign matter such as screws, metal patches, lint, chips, and dust in the option card.
There is risk of fire or accident.
- Do not damage or stress the wiring, **otherwise accident or electric shock may occur.**
- Do not connect the reducer between the motor and the encoder.
There is a risk of accident.

CAUTION

- Do not install or operate a damaged option card or one that is lacking parts, **otherwise injury may occur.**
- Since noise is generated by the inverter, motor, and wiring, carefully monitor surrounding sensors and devices for abnormal operation. **There is a risk of accident.**

(3) Operation

WARNING

- Check and adjust parameters before operation. Improper parameters may cause an unexpected action for some machines. **There is a risk of accident.**

CAUTION

- High-speed operation can be set easily for the inverter. Fully check motor or device performance before changing the setup, **otherwise accident may occur.**

(4) Maintenance and Inspection, and Parts Replacement

WARNING

- Wait at least five minutes after turning off the power before inspecting the option card. (Check whether the charge lamp goes off.) **There is a risk of electric shock.**
Only authorized personnel are allowed to maintain and inspect the option card and replace parts, **otherwise electric shock or injury may occur.**
- Never modify the option card, **otherwise electric shock or injury may occur.**

CAUTION

- Do not execute a megger test (insulation resistance measurement).

(5) Discard

CAUTION

- Since the option card uses soldering lead, treat it as an industrial waste when discarding it.

————— Contents —————

	Page
1. General Information	3
1.1. Introduction to OPC-LM1-IL	3
1.2. Before Using the Option Card	3
1.3. Accessories	3
1.4. Installation Procedure.....	4
1.5. Product Guarantee	6
2. Specifications	6
2.1. Storage Environment.....	6
2.1.1. Temporary Storage	6
2.1.2. Long-term Storage	6
2.2. Operating Environment	7
2.3. Terminal Arrangement	7
2.4. Terminal function and Specifications	8
2.5. Terminal Resistor ON/OFF Switch (SW1)	9
3. Applicable Encoder	10
3.1. Specifications of Applicable Encoder.....	10
3.2. Encoder Installation and Signal	10
4. Wiring.....	11
4.1. Wiring Length and Cable Size.....	11
4.2. Plug	11
4.3. Basic Wiring Diagram.....	12

If anything is unclear about the option card or there is something doubtful about its condition, contact your distributor or our nearest branch office.

1.General Information

1.1.Introduction to OPC-LM1-IL

The high performance vector control of induction motor can be achieved by using this product.

1.2.Before Using the Option Card

Check the items described below when you receive this product. Also check whether this product has been damaged during transport. If anything is amiss, contact your distributor or our nearest branch office.

- (1) The option card is contained in the package.
- (2) The option card is not damaged during transportation-no defective electronic devices, dents or warps.
- (3) The model name "OPC-LM1-IL" is printed on the option card. (See Figure 1.1)

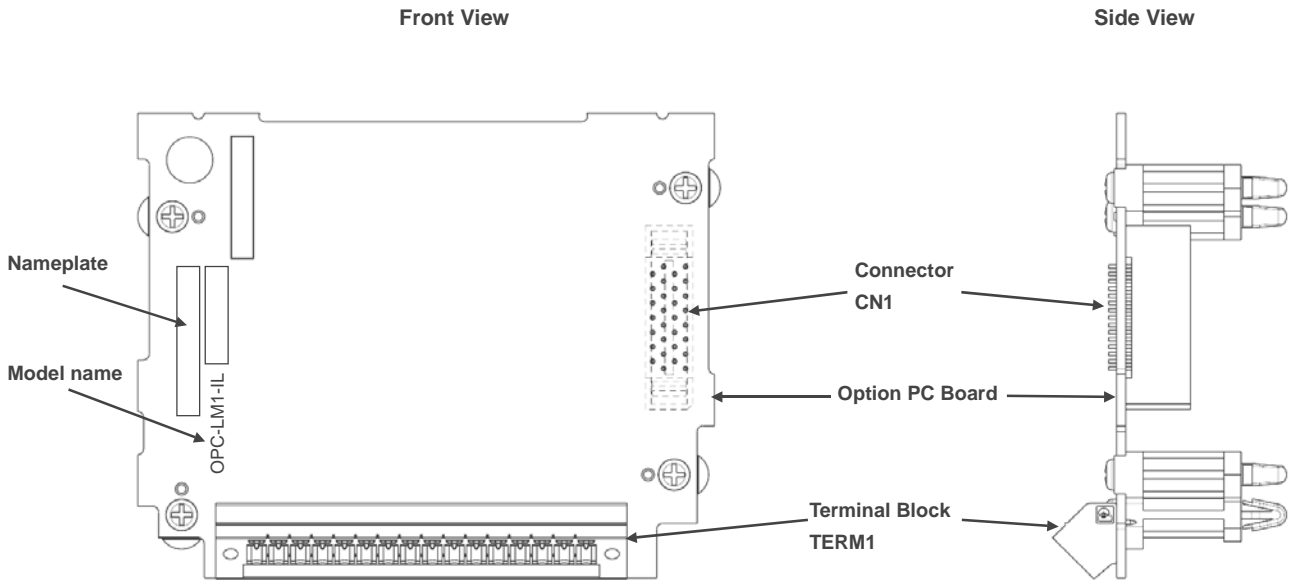

Figure1.1 Product Appearance.

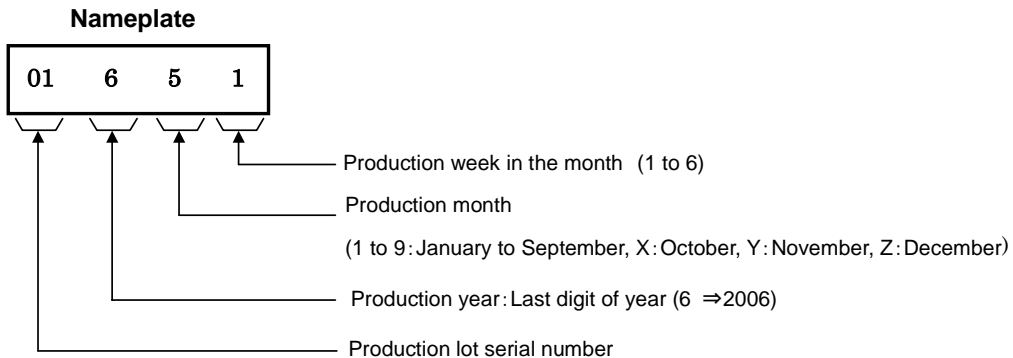

Figure1.2 Nameplate.

1.3.Accessories

Confirm that the following accessories are included in the package:

- | | | |
|-----------------------|-------------------|---------|
| 1. Instruction Manual | | 1 |
| 2. Accessories | 1) Plug for TERM1 | 1 |

1.4. Installation Procedure

WARNING

- Turn off the power and wait for at least five minutes before starting installation. Further, check that the LED monitor is unlit, and check the DC link circuit voltage between the P (+) and N (-) terminals to be lower than 25 VDC.

Otherwise, electric shock could occur.

CAUTION

- Do not touch any metallic part of the connector for the main unit (CN1) or any electronic component. Otherwise, electronic components may be damaged by static electricity charged in your body. Also, the stain or adhesion of sweat or dust may adversely affect the contact reliability of the connector in the long run.

An accident could occur.

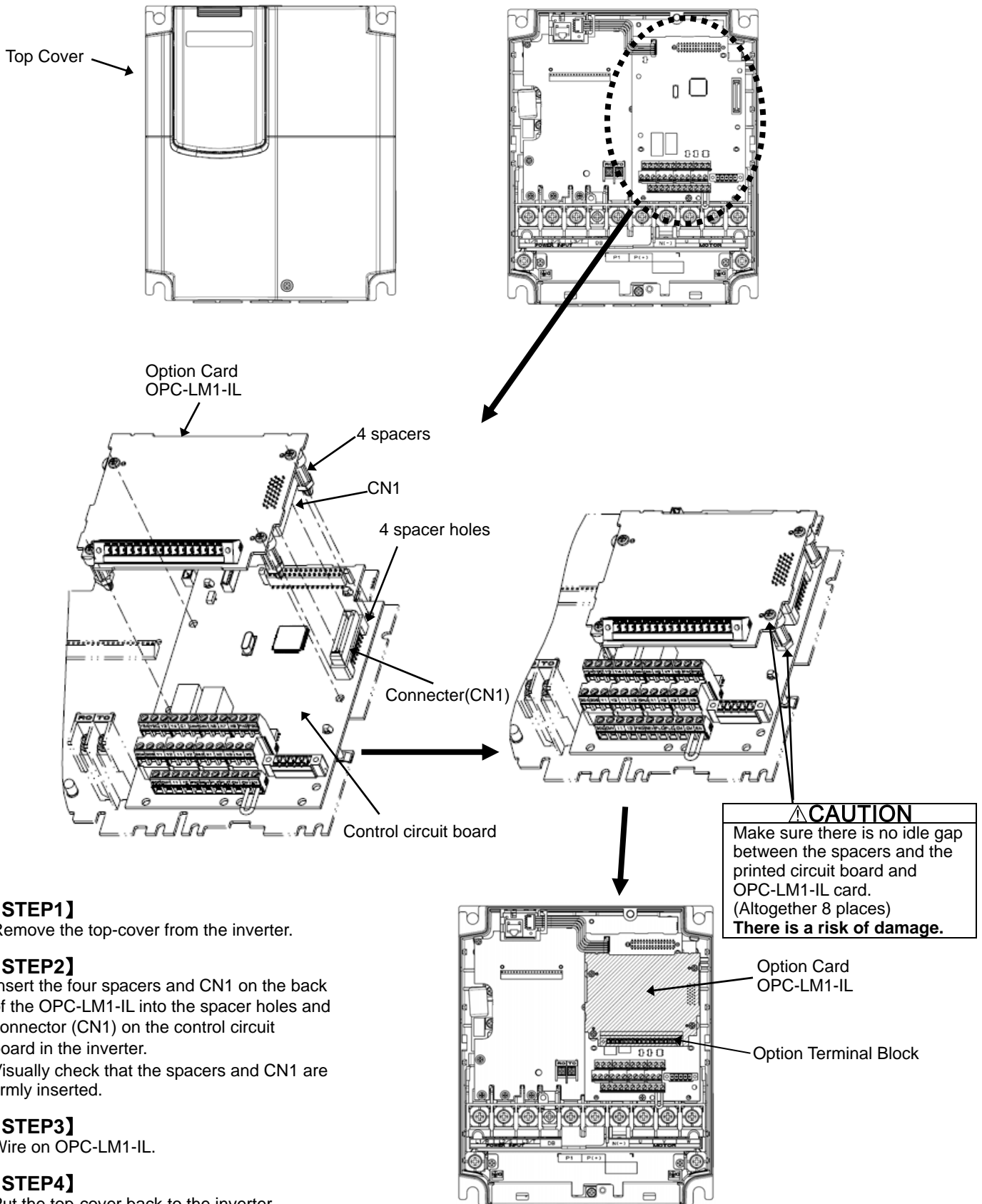

【STEP1】

Remove the top-cover from the inverter.

【STEP2】

Insert the four spacers and CN1 on the back of the OPC-LM1-IL into the spacer holes and connector (CN1) on the control circuit board in the inverter.

Visually check that the spacers and CN1 are firmly inserted.

【STEP3】

Wire on OPC-LM1-IL.

【STEP4】

Put the top-cover back to the inverter.

Figure1.3 Installation drawing

1.5.Product Guarantee

The product guarantee term is one year after installation or two years after manufacturing on the nameplate, whichever expires first.

However, the guarantee will not apply in the following cases, even if the guarantee term has not expired.

- (1) The cause includes incorrect usage or inappropriate repair or modification.
- (2) The product is used outside the standard specified range.
- (3) The failure is caused by dropping, damage or breakage during transportation after the purchase.
- (4) The cause is earthquake, fire, storm or flood, lightening, excessive voltage, or other types of disaster or secondary disasters.

2.Specifications

2.1.Storage Environment

2.1.1.Temporary Storage

Store the option card in an environment that satisfies the requirements listed in Table 2.1.

Table 2.1 Environmental requirements for storage and transportation

Item	Requirements	
Storage Temperature ^{*1}	-25 to 70°C	Location where the option card is not subject to abrupt changes in temperature that would result in the formation of condensation or ice.
Relative humidity	5 to 95% ^{*2}	
Atmosphere	The inverter must not be exposed to dust, direct sunlight, corrosive or flammable gases, oil mist, vapor, water drops or vibration. The atmosphere must contain only a low level of salt. (0.01 mg/cm ² or less per year)	
Atmospheric pressure	86 to 106 kPa (in strage)	
	70 to 106 kPa (during transportation)	

^{*1} Assuming a comparatively short storage period (e.g., during transportation or the like)

^{*2} Even if the humidity is within the specified requirements, avoid such places where the option card will be subjected to sudden changes in temperature that will cause condensation to form.

Precautions for temporary storage

- (1) Do not leave the inverter directly on the floor.
- (2) If the environment does not satisfy the specified requirements, wrap the option card in an airtight vinyl sheet or the like for storage.
- (3) If the option card is to be stored in an environment with a high level of humidity, put a drying agent (such as silica gel) in the airtight package described in item (2).

2.1.2.Long-term Storage

The long-term storage methods for the inverter vary largely according to the environment of the storage site. General storage methods are described below.

- (1) The storage site must satisfy the requirements specified for temporary storage.
- (2) The inverter must be stored in a package that is airtight to protect it from moisture. Include a drying agent inside the package to maintain the relative humidity inside the package to within 70%.
- (3) If the option card has been installed in the equipment or control board at a construction site where it may be subjected to humidity, dust or dirt, then remove the option card and store it in a suitable environment specified in Table 2.1.

2.2.Operating Environment

Install the inverter in an environment that satisfies the requirements listed in Table 2.2.

Table 2.2 Environment requirements

Item	Specifications
Location	Indoors
Ambient temperature	-10 to 45°C
Relative humidity	5 to 95% (No condensation)
Atmosphere	The option card must not be exposed to dust, direct sunlight, corrosive gases, flammable gas, oil mist, vapor or water drops. The atmosphere must contain only a low level of salt. (0.01 mg/cm ² or less per year) The inverter must not be subjected to sudden changes in temperature that will cause condensation to form.
Altitude	1,000 m max. (Note 1)
Vibration	3mm(Max. amplitude):2Hz to 9Hz、9.8m/s ² :9Hz to 20Hz、2m/s ² :20Hz to 55Hz 1m/s ² :55Hz to 200Hz

(Note) If you use the inverter in an altitude above 1000 m, you should apply an output current derating factor as listed in Table 2.3.

Table 2.3 Output Current Derating Factor in Relation to Altitude

Altitude	Output current derating factor
1000 m or lower	1.00
1000 to 1500 m	0.97
1500 to 2000 m	0.95
2000 to 2500 m	0.91
2500 to 3000 m	0.88

2.3.Terminal Arrangement

PO	PO	CM	CM	PA+	PA-	PB+	PB-	PZ+	PZ-	PA+	PA-	PB+	PB-	PZ+	PZ-
----	----	----	----	-----	-----	-----	-----	-----	-----	-----	-----	-----	-----	-----	-----

TERM1

Figure.2.1 Terminal arrangement

2.4. Terminal function and Specifications

Table 2.4 Terminal Specifications

Terminal Symbol	Contents	Specifications
PO	Power supply for encoder	DC5V±5%, MAX 300mA
CM	Common terminal of power supply	DC0V (GND for power supply)
PA+	Pulse terminal A(+)	<ul style="list-style-type: none"> •Line driver input (RS422) •Input frequency Max.125kHz Encoder Accuracy : refer to *A
PA-	Pulse terminal A(-)	
PB+	Pulse terminal B(+)	
PB-	Pulse terminal B(-)	
PZ+	Pulse terminal Z(+)	<ul style="list-style-type: none"> •Line driver input (RS422) Encoder Accuracy : refer to *A
PZ-	Pulse terminal Z(-)	

*A (The accuracy of input terminal PA+, PA-, PB+, PB-,PZ+, PZ-)

The following accuracy is needed at 100kHz inputs.

$$t1, t2, t3, t4 = \left(\frac{1}{4}T\right) \pm \left(\frac{1}{8}T\right)$$

$$e = T \pm \frac{1}{2}T$$

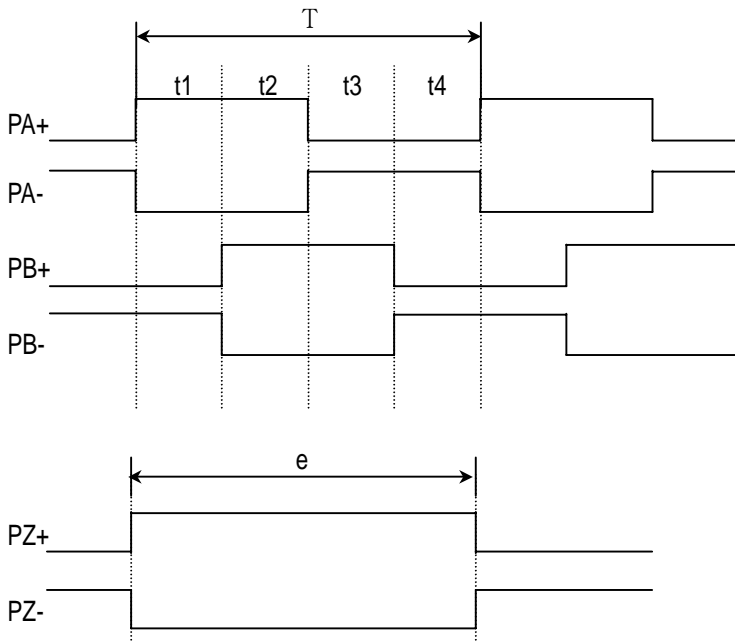

2.5. Terminal Resistor ON/OFF Switch (SW1)

SW1 is a switch for turning on or off the Terminal resistor. (Figure 2.2)

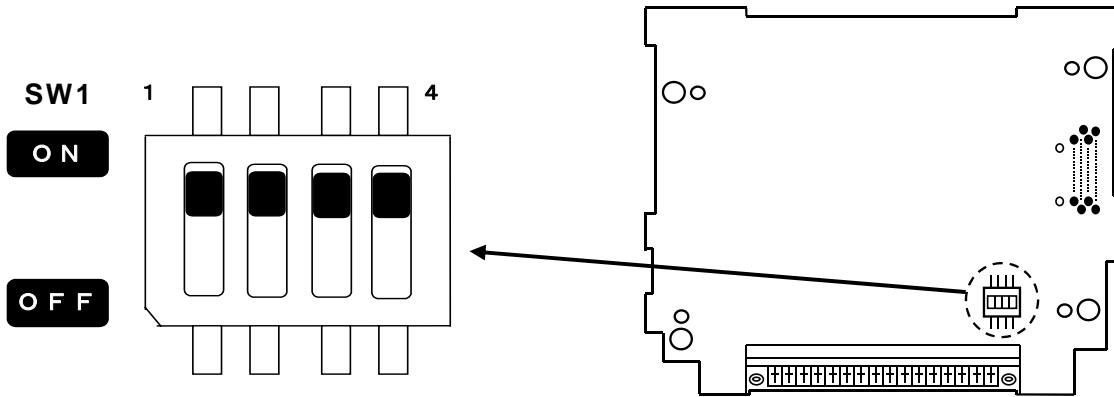

Figure 2.2 Terminal resistor ON/OFF switch (SW1)

(1) Setting of SW1

- If this option is connected with encoder signals (PA+, PA-, PB+, PB-, PZ+ and PZ-) at the termination, place all the selectors of SW1 at the ON side (Factory defaults.)
- If encoder signals (PA+, PA-, PB+, PB-, PZ+ and PZ-) are connected with the controller via this option (that is, the controller is at the termination), place all the selectors of SW1 at the OFF side.

(2) Circuit configuration

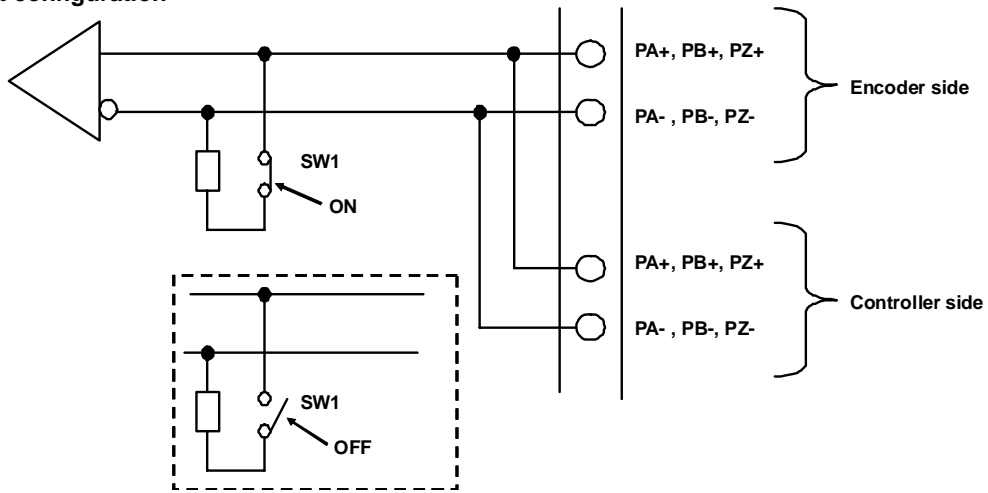

Figure 2.3 Circuit configuration

3.Applicable Encoder

⚠ CAUTION

- Check the encoder specification again before operating the inverter. Improper encoder specification may cause unexpected inverter operation or device operation.
There is a risk of accident or injury.

3.1.Specifications of Applicable Encoder

Table 3.1 Specifications of Applicable encoder.

Item	Specifications	
Applicable Encoder	Pulse encoder frequency	125kHz max, 15kHz or more at the maximum motor speed *1
	Encoder Power Supply	+5Vdc±10% / 300mA
	Pulse Output System	Line driver (AM26LS31)

*1 The setting range is between 360 to 60000 P/R, however the encoder is selected to given the pulse 15kHz or more at maximum motor speed. In case of the low pulse is given, the performance will be worsen.
 e.g.) 1500r/min : 600P/R or more 200r/min : 4500P/R or more

In case of the high frequency pulse is given, it is never exceeded the pulse frequency 125kHz at maximum speed.

3.2.Encoder Installation and Signal

The encoder shall rotate in the direction of Figure 3.1, when terminal FWD is ON.

Encoder output pulse is shown the Figure3.2. Connect the encoder directly to the motor using a coupling.

- 📖 If the encoder is installed to the motor in opposite side of load and the inverter and the motor are wired with UVW order, in the case of JEC standard motor, the rotation is same as shown in Figure 3.1. However in the case of IEC standard motor, the rotation direction becomes opposite. In the case of IEC standard motor, interchange V with W of inverter output and make the motor and encoder rotation direction as shown in Figure 3.1.

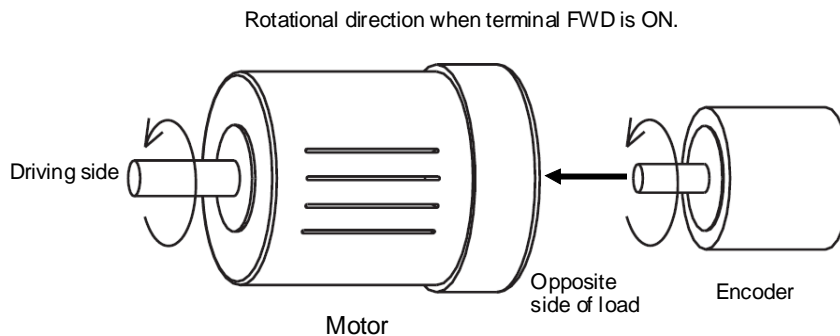

Figure 3.1 Motor and encoder rotational direction when terminal FWD is ON

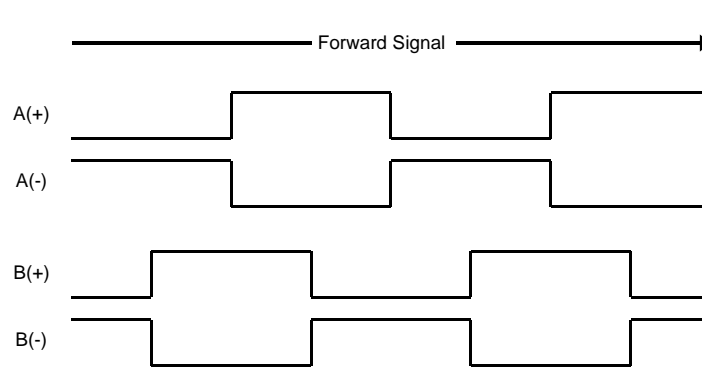

Figure 3.2 Encoder signals

4. Wiring

⚠ CAUTION

- Check the wiring again before operating the inverter. Improper wiring may cause unexpected inverter operation or device operation.
- There is a risk of accident or injury.**

4.1. Wiring Length and Cable Size

Table 4.1 Maximum wiring length

Item	Specification
The maximum wiring length between TERM1 (option card) and encoder	20m
The maximum wiring length between TERM1 (option card) and user controller	5m

Table 4.2 Relation between wire size and wiring length

Encoder specification	Wire length			
	Up to 5m	Up to 10m	Up to 15m	Up to 20m
5V±10%、300mA	0.128mm ² (AWG26)	0.259mm ² (AWG23)	0.412mm ² (AWG21)	0.519mm ² (AWG20)
5V±5%、300mA	0.259mm ² (AWG23)	0.657mm ² (AWG19)	0.811mm ² (AWG18)	1.318mm ² (AWG17)

Wiring of the option card and the encoder

- The wiring of the option card and encoder must use the shield wire. Moreover, the cable length is 20m or less.
- Connect shield of the wire to terminal CM of this option card.
- Separate the wiring of the option card and the wiring of other power lines to prevent the malfunction by the noise. Moreover, never put in the same duct.

4.2. Plug

Applicable terminal plugs

The terminal block for encoder connection is removable type.
The plug (electric wire connection side) is accessories of option card.

Table 4.3 Applicable plug model

Terminal Block	Terminal Plugs Type	Company
TERM1	MC1.5/16-STF-3.81	Phoenix Contact

Specification of plug

Table 4.4 Specification of plug

Item	Specification
Tightening torque	0.22 to 0.25 N·m
Size of screw	M2
Bared wire length	7mm
The applicable maximum wire size	AWG16

(Note) Insert the wire into the upper side of the metal bracket on the terminal block, and tighten the screw.

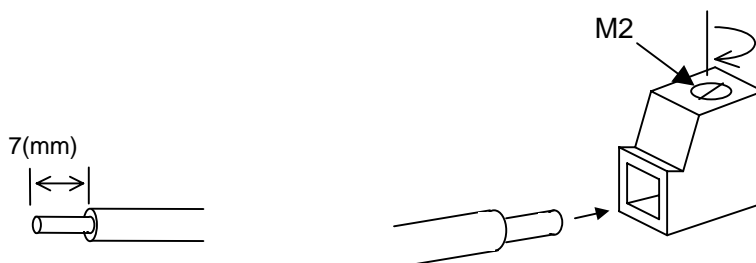

Connection of Wiring on Option
Terminal Side.

4.3. Basic Wiring Diagram

⚠ CAUTION

- Keep the power supply voltage of encoder in the specification voltage of encoder.
There is a risk of failure.

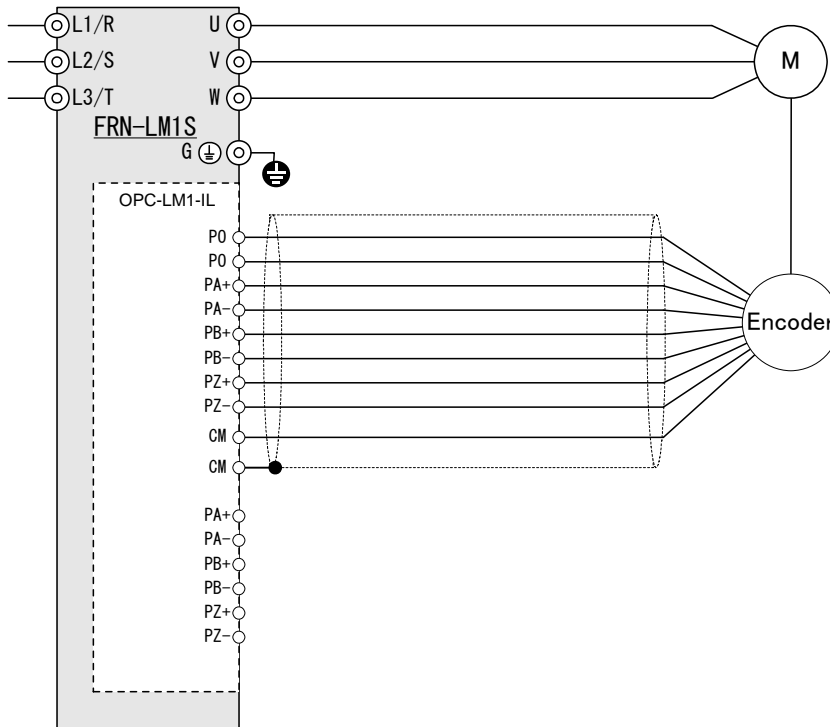

Figure 4.1 When not connecting with the user controller.

* The shielded wires should be connected to CM terminal.

However, when the wires are influenced by induction noise from external devices, you had better connect the shield wires of the encoder side and ground.

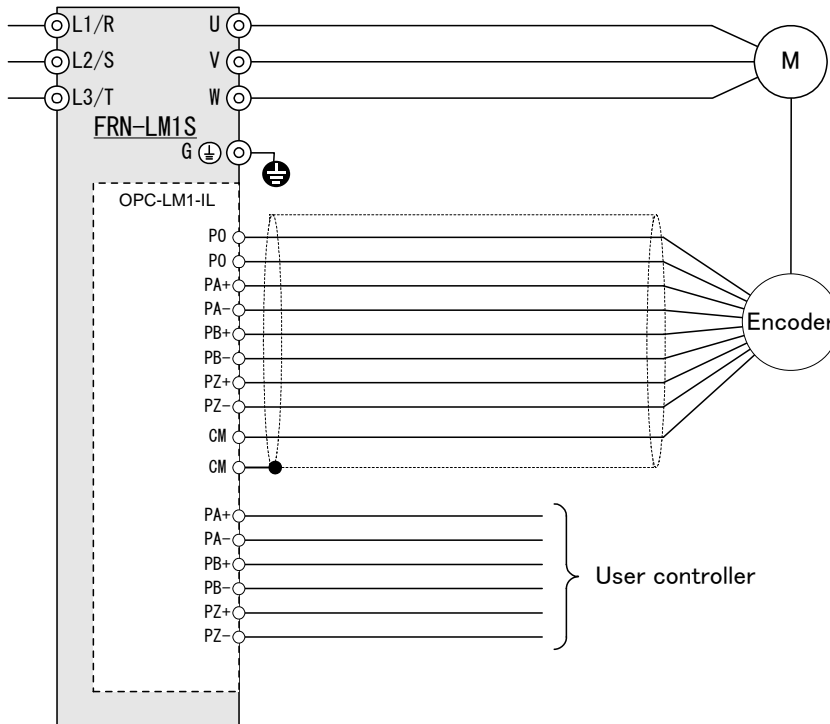

Figure 4.2 When connecting with the user controller.

(Note) In the case of an encoder that connected shield wire and a frame of an encoder, the shield wire should be earthed via the encoder and motor directly.