



Supplement to Functional Safety Inverters

High Performance, Multifunction Inverter

FRENIC-MEGA

This manual is the translation of the original instruction of the original manual, a supplement to the FRENIC-MEGA Instruction Manual (INR-SI47-1223□-E, INR-SI47-1335□-E, INR-SI47-1457□-E), contains descriptions that exclusively apply to the functional safety inverter FRENIC-MEGA (Inverter type: FRN_ _ _G1■-□□). For other descriptions, refer to the FRENIC-MEGA Instruction Manual.

The functional safety inverter FRENIC-MEGA is compliant with European Safety Standard : EN61800-5-2 SIL2 and EN ISO13849-1 PL=d Cat. 3.

To comply with the requirements, refer to the original manual, Chapter 9, Section 9.3 "Compliance with EMC Standards" and Section 9.5 "Compliance with the Low Voltage Directive in the EU" in conjunction with this manual.

Checking the inverter's ROM version

The inverter's ROM version can be checked on Menu #5 "Maintenance Information" (5_ /4) as a 4-digit code. For the detailed keypad operation, refer to the inverter original manuals.

About newly added functions

The functions listed below are newly added to the FRENIC-MEGA series of inverters having a ROM version 3600 or later. For details about those functions, refer to Section 2 "Details of Function Codes Added" or the PG Interface Card Instruction Manual.

Inverter's ROM Version	Newly Added Functions
3600 or later	<ul style="list-style-type: none">(1) Online tuning Performs tuning while the motor is rotating in order to cover the motor speed fluctuation caused by the temperature rise of the motor.(2) Function extension of brake signal Extends the brake-ON sequence function.(3) PG error processing Changes the PG error detection width if the speed command exceeds the base frequency.(4) Synchronous operation Enables synchronous operation of two motors equipped with a pulse generator (PG). The PG interface card (OPC-G1-PG or OPC-G1-PG22) is required. For details, refer to the PG Interface Card Instruction Manual.(5) Motor magnetic flux weakening control under "vector control without speed sensor" Improves the torque control stability. The overspeed detection level can be specified.(6) Improved regenerative power control under vector control Adjusts the motor magnetic flux level to be applied during deceleration under vector control.(7) Terminal command "Enable battery operation" BATRY (Function code data = 59) Cancels the undervoltage protection so that the inverter under an undervoltage condition runs the motor with battery power.(8) "0 to 20 mA" range added to analog input/output(9) Speed limit level adjustable with analog inputs under torque control(10) Adjustable ACR P gain under "vector control"

3700 or later	<p>(1) Terminal command BATRY ("Enable battery operation") (Function code data = 59) Cancels the undervoltage protection so that the inverter under an undervoltage condition runs the motor with battery power.</p> <p>(2) U00 (Customizable logic, Mode selection) that comes to be changeable when the inverter is running</p>
3800 or later	<p>(1) Pattern operation Up to seven stages of pattern operation are possible.</p> <p>(2) Output terminal signals ALI, AL2, AL4 and AL8 (Alarm contents) newly added These signals output the activation status of the inverter protective function.</p> <p>(3) d62 and d63 (Command, Pulse count factors 1 and 2) that come to be changeable when the inverter is running</p>
3900 or later	<p>(1) ASR feed forward gain (d05, A47, b47, r47) Feed forward control is possible in speed control under vector control.</p> <p>(2) Servo lock gain can be selectable in servo lock function Servo lock (gain switching time) (d27), Servo lock (gain 2) (d28) and input terminal signal SLG2 are newly added.</p> <p>(3) Acceleration/Deceleration filter time constant (d86) It specifies the time constant for output frequency under v/f control.</p> <p>(4) Torque monitor (Polarity) (E49) It is possible to set the polarity for the torque related data.</p> <p>(5) Input terminal signal STOP-T (Force to stop only by terminal) The force to stop function that is available by actual terminal only.</p> <p>(6) DC link bus voltage detection level (E76) and output terminal signal U-EDC (low DC link bus voltage) The DC link bus voltage can be checked by the E76 setting value.</p> <p>(7) Output terminal signal IPF2 (Deceleration in momentary power failure) Deceleration condition by momentary power failure can be monitored.</p> <p>(8) FRENIC Loader protocol is selectable in RS-485 communication 2 FRENIC Loader can be connect by port 2 of RS-485 communication link.</p>

 The PG interface card OPC-G1-PG22 is applicable to inverters having a ROM version 3510 or later.

WARNING

In inverters having a ROM version 3600, NEVER use terminal command **BATRY** ("Enable battery operation") since the command does not work normally.

If the inverter runs the motor with battery power for elevating machinery, the load driven may drop due to lack of torque, in the worst case.

Copyright © 2013 Fuji Electric Co., Ltd.
All rights reserved.

No part of this publication may be reproduced or copied without prior written permission from Fuji Electric Co., Ltd.
All products and company names mentioned in this manual are trademarks or registered trademarks of their respective holders.
The information contained herein is subject to change without prior notice for improvement.

List of Errata

The table below provides a list of errata for the FRENIC-MEGA Instruction Manuals (INR-SI47-1183b-E, INR-SI47-1223c-E, INR-SI47-1334-E, INR-SI47-1335a-E and INR-SI47-1457-E).

Page					Wrong	Correct (underlined)
1183b	1223c	1334	1335a	1457		
vii	-	v	-	-	Fuse rating column (IEC number): (FRN3.7G1■-2□/FRN3.7G1■-4□ or lower models) IEC60269-1	IEC60269- <u>2</u>
					Current rating in the fuse rating column: (FRN55G1■-4□) 400 (IEC60269-4)	<u>350</u> (IEC60269-4)
ix	-	vi	-	-	Standard in item 9: EN60204 Appendix C.	<u>IEC60364-5-52</u>
					Note to be added.	<u>In a power supply system (I-T NET) where a neutral point is not grounded, the control terminals are provided with basic insulation from the mains. If a person may touch them directly, an external insulation circuit should be added for double insulation.</u>
						<u>Grounding terminal can accept one wire only.</u>
3-15	-	3-12	-	-	I/O Check Item, <u>4_15, 4_17</u> Shows the pulse rate (p/s) of the A/B phase signal...	Shows the pulse rate of the A/B phase signal... <u>(e.g., 1000 p/s is expressed as 1.00.)</u>
5-7	-	5-7	-	-	Drive control of E31, E32 Torque control: N	Torque control: <u>N</u>
5-10	-	5-9	-	-	C32, C37, C42 Data setting range: 0.00 to 200.00%	0.00 to <u>400.00%</u>
-	-	5-10	-	-	P56 Default setting: 85%	85% (<u>90% for inverters of 132 kW or above</u>)
5-12	-	5-11	-	-	H13 Data setting range: 0.1 to 10.0 s	0.1 to <u>20.0</u> s
					Drive control of H15 w/o PG: Y w/ PG: Y	w/o PG: <u>N</u> w/ PG: <u>N</u>
5-12	-	5-11, 5-100	-	-	H46 Data setting range: 0.1 to 10.0 s	0.1 to <u>20.0</u> s
5-14	5-14	5-12, 5-109	5-12	5-15	H80 Data setting range: 0.00 to 0.40 Drive control: Torque Control :Y	0.00 to <u>1.00</u> Torque Control : <u>N</u>
5-14	-	5-12	-	-	Drive control of H92, H93 w/o PG: Y w/ PG: Y	w/o PG: <u>N</u> w/ PG: <u>N</u>
5-16, 5-18, 5-20	-	5-14, 5-16, 5-18	-	-	A56, b56, r56 Default setting: 85%	85% (<u>90% for inverters of 132 kW or above</u>)
5-22	-	5-19	-	-	d55 Data setting range: 0, 1	<u>0000 to 00FF (in hex.)</u>
					d55 Default setting: 0	<u>0000</u>
5-22	5-22	5-19	5-19	-	d68 Default setting: 40	<u>4.0</u>

Page					Wrong	Correct (underlined)
1183b	1223c	1334	1335a	1457		
5-85, 5-87	-	5-110, 5-111	-	-	H81, H82: Light Alarm Selection 1 and 2 "PID feedback wire break" to be added.	<u>Addition of Light Alarm Factor</u> Code: <u>L₀F</u> Name: <u>PID feedback wire break</u> Description: <u>The PID feedback signal wire(s) is broken.</u> <u>Table 5.2 Light Alarm Selection 2 (H82), Bit Assignment of Selectable Factors</u> Bit: <u>3</u> Code: <u>L₀F</u> Content: <u>PID feedback wire break</u>
5-92	-	5-117	-	-	Table 5.5 Function Codes to be Switched Last line Reserved: d57 A57, b57, r57	<u>P57, A57, b57, r57</u>
-	-	5-127	-	-	J62 PID Control (PID control block selection) Table When J62 = 0, 1: Absolute value (Hz) When J62 = 2,3: Ratio (%)	When J62 = 0, 1: <u>Ratio (%)</u> When J62 = 2,3: <u>Absolute value (Hz)</u>
-	-	8-2 to 8-4	8-2 to 8-4	-	Noncompliance note to be added to "Applicable safety standards C22.2 No. 14."	<u>The following inverters are not compliant with C22.2 No. 14.</u> <u>FRN160G1■-4□ to FRN220G1■-4□</u> <u>FRN355G1■-4□, FRN400G1■-4□</u>

Chapter 2

2.3.2 Terminal arrangement diagram and screw specifications

(2) Arrangement of control circuit terminals (common to all inverter types)

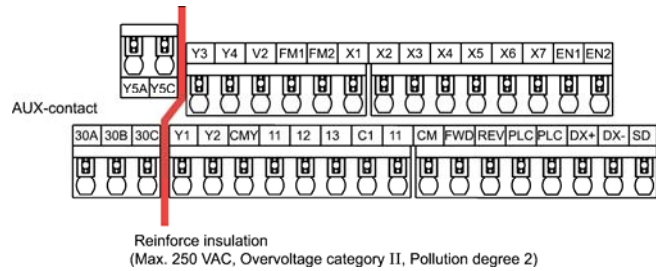
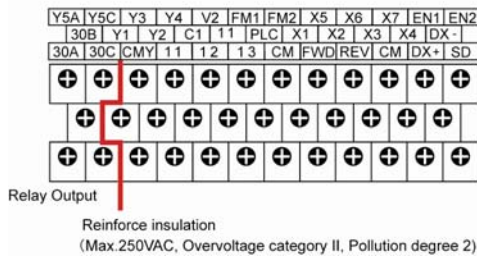

Terminal type	Screw size: M3 (0.7 N·m)	Spring (screwless)
Recommended wiring size (mm ²)*	0.75	0.65 to 0.82 (AWG 19 or 18)

* Using wires exceeding the recommended sizes may lift the front cover depending upon the number of wires used, impeding keypad's normal operation.

2.3.5 Wiring of main circuit terminals and grounding terminals

This section shows connection diagrams with the Enable input function used.

- (1) FRN___G1■-2A/2U/4A/4U, with SINK mode input by factory default
- (2) FRN___G1■-4E, with SOURCE mode input by factory default

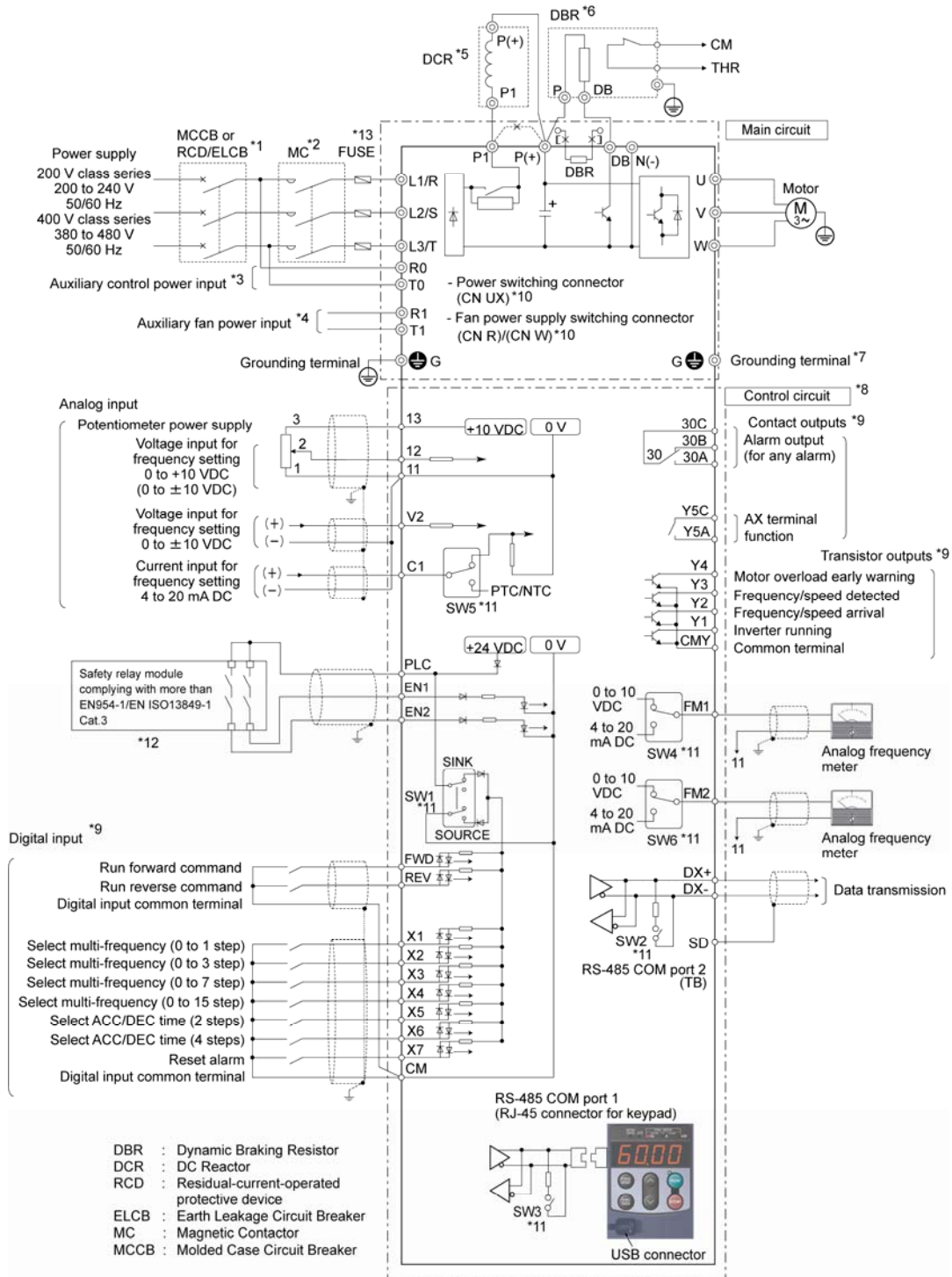

- *1 Install a recommended molded case circuit breaker (MCCB) or residual-current-operated protective device (RCD)/earth leakage circuit breaker (ELCB) (with overcurrent protection function) in the primary circuit of the inverter to protect wiring. Ensure that the circuit breaker capacity is equivalent to or lower than the recommended capacity.
- *2 Install a magnetic contactor (MC) for each inverter to separate the inverter from the power supply, apart from the MCCB or RCD/ELCB, when necessary.
Connect a surge absorber in parallel when installing a coil such as the MC or solenoid near the inverter.
- *3 The R0 and T0 terminals are provided for inverters with a capacity of 1.5 kW/2 HP or above.
To retain an alarm output signal *ALM* issued on inverter's programmable output terminals by the protective function or to keep the keypad alive even if the main power has shut down, connect these terminals to the power supply lines. Without power supply to these terminals, the inverter can run.
- *4 Normally no need to be connected. Use these terminals when the inverter is equipped with a high power-factor, regenerative PWM converter (RHC series).
- *5 When connecting an optional DC reactor (DCR), remove the jumper bar from the terminals P1 and P(+).
Inverters with a capacity of 55 kW/100 HP in LD mode and inverters with 75 kW/125 HP or above require a DCR to be connected. Be sure to connect it to those inverters.
Use a DCR when the capacity of the power supply transformer exceeds 500 kVA and is 10 times or more the inverter rated capacity, or when there are thyristor-driven loads in the same power supply line.
- *6 Inverters with a capacity of 7.5 kW/15 HP or below have a built-in braking resistor (DBR) between the terminals P(+) and DB.
When connecting an external braking resistor (DBR), be sure to disconnect the built-in one.
- *7 A grounding terminal for a motor. Use this terminal if needed.
- *8 For control signal wires, use twisted or shielded-twisted wires. When using shielded-twisted wires, connect the shield of them to the common terminals of the control circuit. To prevent malfunction due to noise, keep the control circuit wiring away from the main circuit wiring as far as possible (recommended: 10 cm/3.9 inches or more). Never install them in the same wire duct. When crossing the control circuit wiring with the main circuit wiring, set them at right angles.
- *9 The connection diagram shows factory default functions assigned to digital input terminals [X1] to [X7], [FWD] and [REV], transistor output terminals [Y1] to [Y4], and relay contact output terminals [Y5A/C] and [30A/B/C].
- *10 Switching connectors in the main circuits. For details, refer to "Instruction manual for FRENIC-MEGA Section 2.3.4 ⑥ Switching connectors" later in this section.
- *11 Slide switches on the control printed circuit board (control PCB). Use these switches to customize the inverter operations. For details, refer to Instruction manual for FRENIC-MEGA Section 2.3.6 "Setting up the slide switches."
- *12 When the Enable input function is not to be used, keep terminals [EN1]-[PLC] and terminals [EN2]-[PLC] short-circuited using jumper wires. For opening and closing the hardware circuit between terminals [EN1] and [PLC] and between [EN2] and [PLC], use safety components such as safety relays and safety switches that comply with EN954-1 or EN ISO13849-1 Category 3 or higher.
- *13 To bring the inverter into compliance with the European Standard, Low Voltage Directive EN61800-5-1, be sure to insert the specified fuse (see Instruction manual for FRENIC-MEGA page v) in the primary circuit of the inverter.

2.3.6 Wiring for control circuit terminals

⚠ WARNING
<p>In general, the covers of the control signal wires are not specifically designed to withstand a high voltage (i.e., reinforced insulation is not applied). Therefore, if a control signal wire comes into direct contact with a live conductor of the main circuit, the insulation of the cover might break down, which would expose the signal wire to a high voltage of the main circuit. Make sure that the control signal wires will not come into contact with live conductors of the main circuit.</p> <p>Failure to observe these precautions could cause electric shock or an accident.</p>

⚠ CAUTION
<p>Noise may be emitted from the inverter, motor and wires. Take appropriate measures to prevent the nearby sensors and devices from malfunctioning due to such noise.</p> <p>An accident could occur.</p>

■ Connecting/disconnecting wires to/from a control circuit terminal of spring(screwless) type

- ① Strip the wire end by 8 to 10 mm/0.31 to 0.39 inch as shown below.

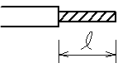
Strip length of wire end	8 to 10 mm 0.31 to 0.39 inch	
Type of screwdriver (tip shape)	Flat (0.6 × 3.5 mm/0.024 × 0.14 inch)	

Note For strand wires, the strip length specified above should apply after twisting of them.
If the strip length is out of the specified range, the wire may not be firmly clamped or may be short-circuited with other wires.

- ② Twist the end of the stripped wires for easy insertion and insert it firmly into the wire inlet on the control circuit terminal. If the insertion is difficult, hold down the clamp release button on the terminal with a flat screwdriver.
- ③ When disconnecting the wires from the terminal, hold down the clamp release button on the terminal with a flat screwdriver and pull out the wires.

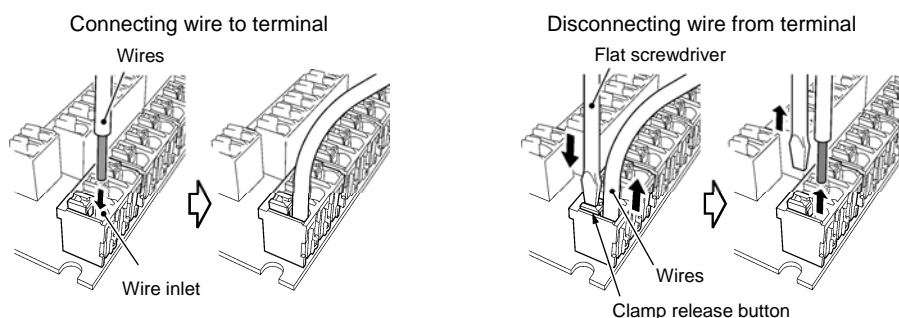
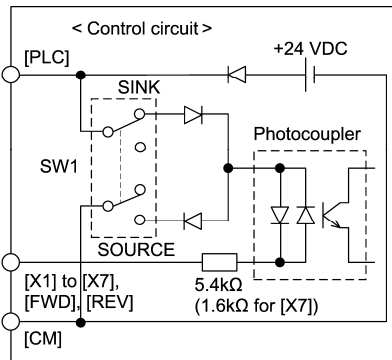

Table 2.7 lists the symbols, names and functions of the control circuit terminals. The wiring to the control circuit terminals differs depending upon the setting of the function codes, which reflects the use of the inverter. Route wires properly to reduce the influence of noise.

Table 2.7 Symbols, Names and Functions of the Control Circuit Terminals

Classification	Symbol	Name	Functions																									
Analog input	[C1]	Analog setting current input	<p>(1) The frequency is commanded according to the external current input.</p> <ul style="list-style-type: none"> • 4 to 20 mA DC/0 to 100% (Normal operation) • 20 to 4 mA DC/0 to 100 % (Inverse operation) <p>(2) In addition to frequency setting, PID command, PID feedback signal, auxiliary frequency command setting, ratio setting, torque limiter level setting, or analog input monitor can be assigned to this terminal.</p> <p>(3) Hardware specifications</p> <ul style="list-style-type: none"> • Input impedance: 250Ω • The maximum input is +30 mA DC, however, the current larger than +20 mA DC is handled as +20 mA DC. 																									
		PTC/NTC thermistor input	<p>(1) Connects PTC (Positive Temperature Coefficient)/NTC (Negative Temperature Coefficient) thermistor for motor protection. Ensure that the slide switch SW5 on the control PCB is turned to the PTC/NTC position (see Instruction manual for FRENIC-MEGA Section 2.3.6 "Setting up the slide switches").</p> <p>The figure shown at the right illustrates the internal circuit diagram where SW5 (switching the input of terminal [C1] between C1 and PTC/NTC) is turned to the PTC/NTC position. For details on SW5, refer to Instruction manual for FRENIC-MEGA Section 2.3.6 "Setting up the slide switches." In this case, you must change data of the function code H26.</p>																									
Digital input	[X1]	Digital input 1	<p>(1) Various signals such as "Coast to a stop," "Enable external alarm trip," and "Select multi-frequency" can be assigned to terminals [X1] to [X7], [FWD] and [REV] by setting function codes E01 to E07, E98, and E99. For details, refer to Chapter 5, Section 5.2 "Details of Function Codes."</p> <p>(2) Input mode, i.e. SINK/SOURCE, is changeable by using the slide switch SW1. (Refer to Instruction manual for FRENIC-MEGA Section 2.3.6 "Setting up the slide switches.")</p> <p>(3) Switches the logic value (1/0) for ON/OFF of the terminals [X1] to [X7], [FWD], or [REV]. If the logic value for ON of the terminal [X1] is 1 in the normal logic system, for example, OFF is 1 in the negative logic system and vice versa.</p> <p>(4) Digital input terminal [X7] can be defined as a pulse train input terminal with the function codes.</p>																									
	[X2]	Digital input 2																										
	[X3]	Digital input 3																										
	[X4]	Digital input 4																										
	[X5]	Digital input 5																										
	[X6]	Digital input 6																										
	[X7]	Digital input 7																										
	[FWD]	Run forward command	<p>Maximum wiring length 20 m/66 ft</p> <p>Maximum input pulse 30 kHz: When connected to a pulse generator with open collector transistor output (Needs a pull-up or pull-down resistor. See notes on page 2-22.)</p> <p>100 kHz: When connected to a pulse generator with complementary transistor output</p> <p>For the settings of the function codes, refer to FRENIC-MEGA User's Manual, Chapter 5 "FUNCTION CODES."</p>																									
[REV]	Run reverse command	<p>(Digital input circuit specifications)</p>  <table border="1" data-bbox="949 1787 1388 2094"> <thead> <tr> <th colspan="2">Item</th> <th>Min.</th> <th>Max.</th> </tr> </thead> <tbody> <tr> <td rowspan="2">Operating voltage (SINK)</td> <td>ON level</td> <td>0 V</td> <td>2 V</td> </tr> <tr> <td>OFF level</td> <td>22 V</td> <td>27 V</td> </tr> <tr> <td rowspan="2">Operating voltage (SOURCE)</td> <td>ON level</td> <td>22 V</td> <td>27 V</td> </tr> <tr> <td>OFF level</td> <td>0 V</td> <td>2 V</td> </tr> <tr> <td colspan="2">Operating current at ON (Input voltage is at 0 V) (For [X7])</td> <td>2.5 mA</td> <td>5 mA</td> </tr> <tr> <td colspan="2">Allowable leakage current at OFF</td> <td>-</td> <td>0.5 mA</td> </tr> </tbody> </table>	Item		Min.	Max.	Operating voltage (SINK)	ON level	0 V	2 V	OFF level	22 V	27 V	Operating voltage (SOURCE)	ON level	22 V	27 V	OFF level	0 V	2 V	Operating current at ON (Input voltage is at 0 V) (For [X7])		2.5 mA	5 mA	Allowable leakage current at OFF		-	0.5 mA
Item		Min.	Max.																									
Operating voltage (SINK)	ON level	0 V	2 V																									
	OFF level	22 V	27 V																									
Operating voltage (SOURCE)	ON level	22 V	27 V																									
	OFF level	0 V	2 V																									
Operating current at ON (Input voltage is at 0 V) (For [X7])		2.5 mA	5 mA																									
Allowable leakage current at OFF		-	0.5 mA																									

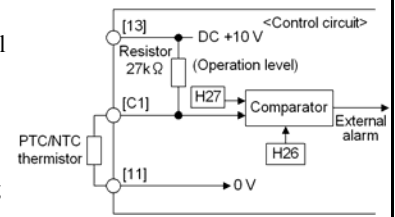

Figure 2.10 Internal Circuit Diagram (SW5 Selecting PTC/NTC)

Figure 2.13 Digital Input Circuit

Table 2.7 Symbols, Names and Functions of the Control Circuit Terminals (Continued)

Classification	Symbol	Name	Functions																
Digital input	[EN1] [EN2]	Enable input	<p>(1) Turning off the circuit between terminals [EN1] and [PLC] or terminals [EN2] and [PLC] stops the inverter's output transistor. (Safe Torque Off: STO)</p> <p>(2) These terminals are exclusively used for the source mode input and cannot be switched to the sink mode.</p> <p>(3) If either one of these input terminals is kept OFF for 50 ms or more, the inverter interprets it as a discrepancy, causing an alarm E_{LF}. This alarm state can be cleared only by turning the inverter power off and on clears this alarm.</p> <p><Digital input circuit specifications></p>  <table border="1" data-bbox="893 582 1356 795"> <thead> <tr> <th>Item</th> <th>Min.</th> <th>Max.</th> </tr> </thead> <tbody> <tr> <td rowspan="2">Operating voltage</td> <td>ON level</td> <td>22 V</td> <td>27 V</td> </tr> <tr> <td>OFF level</td> <td>0 V</td> <td>2 V</td> </tr> <tr> <td>Operating current at ON (Input voltage is at 27 V)</td> <td>2.5 mA</td> <td>5 mA</td> </tr> <tr> <td>Allowable leakage current at OFF</td> <td>-</td> <td>0.5 mA</td> </tr> </tbody> </table>	Item	Min.	Max.	Operating voltage	ON level	22 V	27 V	OFF level	0 V	2 V	Operating current at ON (Input voltage is at 27 V)	2.5 mA	5 mA	Allowable leakage current at OFF	-	0.5 mA
	Item	Min.	Max.																
	Operating voltage	ON level	22 V	27 V															
OFF level		0 V	2 V																
Operating current at ON (Input voltage is at 27 V)	2.5 mA	5 mA																	
Allowable leakage current at OFF	-	0.5 mA																	
[PLC]	PLC signal power	<p>(1) Connects to the power supply of PLC output signals. Rated voltage: +24 VDC (Allowable range: +22 to +27 VDC), Maximum 100 mA DC</p> <p>(2) This terminal also supplies power to the load connected to the transistor output terminals. Refer to "Transistor output" described later in this table for more.</p>																	
[CM]	Digital input common	<p>Common terminal for digital input signals This terminal is electrically isolated from the terminals [11]s and [CMY].</p>																	
Tip	<p>■ Using a relay contact to turn [X1] to [X7], [FWD], or [REV] ON or OFF</p> <p>Figure 2.14 shows two examples of a circuit that uses a relay contact to turn control signal input [X1] to [X7], [FWD], or [REV] ON or OFF. In circuit (a), the slide switch SW1 is turned to SINK, whereas in circuit (b) it is turned to SOURCE.</p> <p>Note: To configure this kind of circuit, use a highly reliable relay. (Recommended product: Fuji control relay Model HH54PW.)</p>  <p>(a) With the switch turned to SINK</p> <p>(b) With the switch turned to SOURCE</p> <p>Figure 2.14 Circuit Configuration Using a Relay Contact</p>																		
Tip	<p>■ Using a programmable logic controller (PLC) to turn [X1] to [X7], [FWD], or [REV] ON or OFF</p> <p>Figure 2.15 shows two examples of a circuit that uses a programmable logic controller (PLC) to turn control signal input [X1] to [X7], [FWD], or [REV] ON or OFF. In circuit (a), the slide switch SW1 is turned to SINK, whereas in circuit (b) it is turned to SOURCE.</p> <p>In circuit (a) below, short-circuiting or opening the transistor's open collector circuit in the PLC using an external power supply turns ON or OFF control signal [X1] to [X7], [FWD], or [REV]. When using this type of circuit, observe the following:</p> <ul style="list-style-type: none"> - Connect the + node of the external power supply (which should be isolated from the PLC's power) to terminal [PLC] of the inverter. - Do not connect terminal [CM] of the inverter to the common terminal of the PLC. 																		

Table 2.7 Symbols, Names and Functions of the Control Circuit Terminals (Continued)

Classification	Symbol	Name	Functions																							
Digital input																										
	<p>(a) With the switch turned to SINK</p> <p>(b) With the switch turned to SOURCE</p> <p>Figure 2.15 Circuit Configuration Using a PLC</p> <p>For details about the slide switch setting, refer to Instruction manual for FRENIC-MEGA Section 2.3.6 "Setting up the slide switches."</p> <p>Note</p> <ul style="list-style-type: none"> For inputting a pulse train through the digital input terminal [X7] <ul style="list-style-type: none"> Inputting from a pulse generator with an open collector transistor output <p>Stray capacity on the wiring between the pulse generator and the inverter may disable transmission of the pulse train. As a countermeasure against this problem, insert a pull-up resistor between the open collector output signal (terminal [X7]) and the power source terminal (terminal [PLC]) if the switch selects the SINK mode input; insert a pull-down resistor between the output signal and the digital common terminal (terminal [CM]) if the switch selects the SOURCE mode input.</p> <p>A recommended pull-up/down resistor is 1kΩ 2 W. Check if the pulse train is correctly transmitted because stray capacity is significantly affected by the wire types and wiring conditions.</p>																									
Analog output	<p>[FM1] [FM2]</p> <p>Analog monitor</p>		<p>Both terminals output monitor signals for analog DC voltage (0 to +10 V) or analog DC current (+4 to +20 mA). The output form (VO/IO) for each of [FM1] and [FM2] can be switched with the slide switches on the control PCB and the function codes, as listed below.</p> <table border="1" data-bbox="523 1104 1374 1288"> <thead> <tr> <th rowspan="2">Terminal</th> <th rowspan="2">Terminal function is specified by:</th> <th colspan="2">Output form</th> <th rowspan="2">Content is specified by:</th> </tr> <tr> <th>Analog DC voltage</th> <th>Analog DC current</th> </tr> </thead> <tbody> <tr> <td rowspan="2">[FM1]</td> <td>Slide switch SW4</td> <td>VO1</td> <td>IO1</td> <td rowspan="2">Function code F31</td> </tr> <tr> <td>Function code F29</td> <td>0</td> <td>1</td> </tr> <tr> <td rowspan="2">[FM2]</td> <td>Slide switch SW6</td> <td>VO2</td> <td>IO2</td> <td rowspan="2">Function code F35</td> </tr> <tr> <td>Function code F32</td> <td>0</td> <td>1</td> </tr> </tbody> </table> <p>The signal content can be selected from the following with function codes F31 and F35.</p> <ul style="list-style-type: none"> Output frequency Output torque PID feedback amount Universal AO PID command Output current Load factor Speed (PG feedback value) Motor output PID output Output voltage Input power DC link bus voltage Calibration <p>* Input impedance of the external device: Min. 5kΩ (at 0 to 10 VDC output) (While the terminal is outputting 0 to 10 VDC, it is capable of driving up to two analog voltmeters with 10 kΩ impedance.)</p> <p>* Input impedance of the external device: Max. 500Ω (at 4 to 20 mA DC output)</p> <p>* Adjustable range of the gain: 0 to 300%</p>	Terminal	Terminal function is specified by:	Output form		Content is specified by:	Analog DC voltage	Analog DC current	[FM1]	Slide switch SW4	VO1	IO1	Function code F31	Function code F29	0	1	[FM2]	Slide switch SW6	VO2	IO2	Function code F35	Function code F32	0	1
	Terminal	Terminal function is specified by:	Output form			Content is specified by:																				
Analog DC voltage			Analog DC current																							
[FM1]	Slide switch SW4	VO1	IO1	Function code F31																						
	Function code F29	0	1																							
[FM2]	Slide switch SW6	VO2	IO2	Function code F35																						
	Function code F32	0	1																							
<p>[11]</p> <p>Analog common</p>		<p>Two common terminals for analog input and output signals. These terminals are electrically isolated from terminals [CM] and [CMY].</p>																								

Chapter 3

Monitoring the running status -- Menu #3 "Drive Monitoring" --

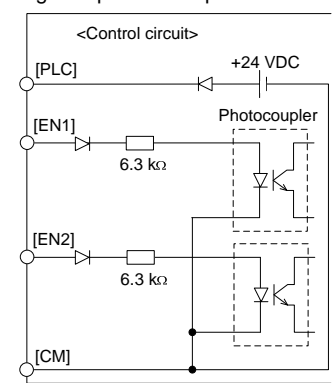
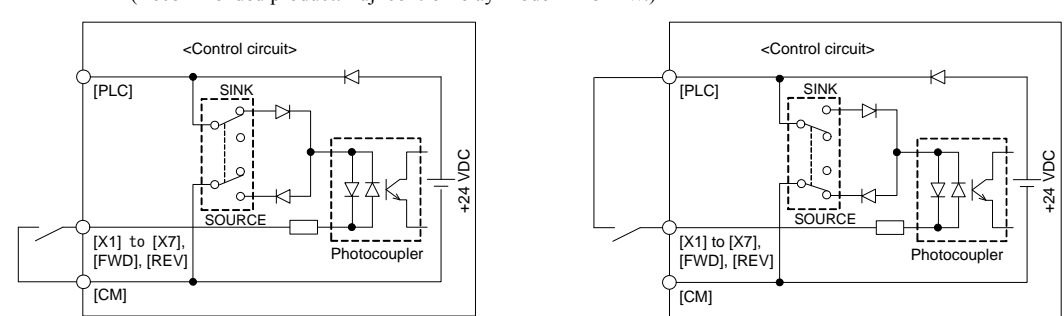
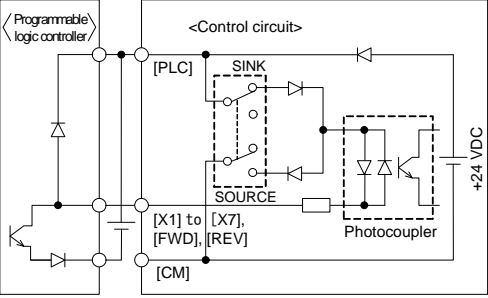
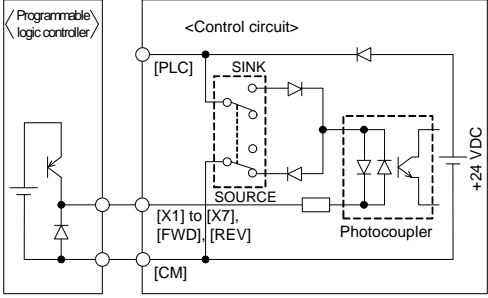
Listed below are monitoring items added or modified in the FRENIC-MEGA series of inverters having a ROM version 3000 or later.

LED monitor shows:	Item	Unit	Description
3-17	Target position pulse (synchronous operation)	Pulse	Shows the target position pulse for synchronous operation.
3-18	Current position pulse (synchronous operation)	Pulse	Shows the current position pulse for synchronous operation.
3-19	Current deviation pulse (synchronous operation)	Pulse	Shows the current deviation pulse for synchronous operation.
3-20	Control status monitor (synchronous operation)	--	Shows the current control status. 0: Synchronous operation disabled 20: Synchronous operation canceled 21: Synchronous operation stopped 22: Waiting for detection of Z phase 23: Z phase of reference PG detected 24: Z phase of slave PG detected 25: Synchronization in progress 26: Synchronization completed
3-26	Positioning deviation (synchronous operation)	degree	Shows the positioning deviation (in degree) for synchronous operation.

Note

Difference of notation between standard keypad and remote keypad

Descriptions in this manual are based on the standard keypad having a *four*-digit, 7-segment LED monitor (shown in the original FRENIC-MEGA Instruction Manuals, Chapter 3). The FRENIC-MEGA also provides a multi-function keypad as an option, which has an LCD monitor and a *five*-digit, 7-segment LED, but has no USB port.

If the standard keypad is replaced with an optional multi-function keypad, the display notation differs as shown below.

Function code	Name	Standard keypad	Multi-function keypad (TP-G1-J1)
H42	Capacitance of DC Link Bus Capacitor	Hexadecimal notation	Decimal notation
H44	Startup Counter for Motor 1		
H47	Initial Capacitance of DC Link Bus Capacitor		
H79	Preset Startup Count for Maintenance (M1)		
A52	Startup Counter for Motor 2		
b52	Startup Counter for Motor 3		
r52	Startup Counter for Motor 4		
d15	Feedback Input (Encoder pulse resolution)		
d60	Command (Pulse Rate Input) (Encoder pulse resolution)	Display in units of 10 hours	Display by hours
H43	Cumulative Run Time of Cooling Fan		
H48	Cumulative Run Time of Capacitors on Printed Circuit Boards		
H77	Service Life of DC Link Bus Capacitor (Remaining time)		
H78	Maintenance Interval (M1)		
H94	Cumulative Motor Run Time 1		
A51	Cumulative Motor Run Time 2		
b51	Cumulative Motor Run Time 3		
r51	Cumulative Motor Run Time 4	Display in units of 10 pulses. (For 10000 pulses or more: Display in units of 100 pulses, with the x10 LED ON)	Display in units of 10 pulses
d78	Synchronous Operation (Excessive deviation detection range)		

Chapter 5

Chapter 5-1 Function Code Tables

Listed below are function codes added or modified in the FRENIC-MEGA series of inverters having a ROM version 3600 or later.

Code	Name	Data setting range	Change when running	Data copying	Default setting	Drive control					Refer to page:
						V/f	PG V/f	w/o PG	w/ PG	Torque control	
F01	Frequency Command 1	10: Pattern operation	N	Y	0	Y	Y	Y	Y	N	17
F29 *1	Analog Output [FMA]/[FM1] (Mode selection)	0: Output in voltage (0 to 10 VDC) 1: Output in current (4 to 20 mA DC) 2: Output in current (0 to 20 mA DC)	Y	Y	0	Y	Y	Y	Y	Y	17
F31 *1	Analog Output [FMA]/[FM1] (Function)	17: Positional deviation in synchronous operation	Y	Y	0	N	Y	N	Y	N	17
F32	Analog Output [FM2] (Mode selection)	0: Output in voltage (0 to 10 VDC) 1: Output in current (4 to 20 mA DC) 2: Output in current (0 to 20 mA DC)	Y	Y	0	Y	Y	Y	Y	Y	17
F35 *1	Pulse Output [FMP] Analog Output [FM2] (Function)		Y	Y	0	N	Y	N	Y	N	17
E01	Terminal [X1] Function	59 (1059): Enable battery operation (BATRY)	N	Y	0	Y	Y	Y	Y	Y	18
E02	Terminal [X2] Function	110(1110): Servo lock gain selection (SLG2)	N	Y	1	N	N	N	Y	N	18
E03	Terminal [X3] Function	111(1111): Force to stop only by terminal (STOP-T)	N	Y	2	Y	Y	Y	Y	Y	18
E04	Terminal [X4] Function	(111 = Active OFF, 1111 = Active ON)	N	Y	3						18
E05	Terminal [X5] Function		N	Y	4						18
E06	Terminal [X6] Function		N	Y	5						18
E07	Terminal [X7] Function		N	Y	+3						18
E08 *2	Terminal [X8] Function		N	Y	7						18
E09 *2	Terminal [X9] Function		N	Y	8						18
E20	Terminal [Y1] Function	16 (1016): Stage transition signal for pattern operation (TU)	N	Y	0	Y	Y	Y	Y	N	21
E21	Terminal [Y2] Function	17 (1017): Cycle completion signal for pattern operation (TO)	N	Y	1	Y	Y	Y	Y	N	21
E22	Terminal [Y3] Function	18 (1018): Pattern operation stage 1 (STG1)	N	Y	2	Y	Y	Y	Y	N	21
E23	Terminal [Y4] Function	19 (1019): Pattern operation stage 2 (SRG2)	N	Y	7	Y	Y	Y	Y	N	21
E24	Terminal [Y5A/C] Function	20 (1020): Pattern operation stage 4 (STG4)	N	Y	15	Y	Y	Y	Y	N	21
E27	Terminal [30A/B/C] Function	29 (1029): Synchronization completed (SY) 77 (1077): Low DC link bus voltage (U-EDC) 79 (1079): Deceleration in momentary power failure (IPF2) 90 (1090): Alarm indication 1 (AL1) 91 (1091): Alarm indication 2 (AL2) 92 (1092): Alarm indication 4 (AL4) 93 (1093): Alarm indication 8 (AL8)	N	Y	99	N	Y	N	Y	N	21
E49	Torque monitor (Polarity)	0: Torque polarity 1: + for driving, - for braking	Y	Y	1	Y	Y	Y	Y	Y	24
E61	Terminal [12] Extended Function	17: Speed limit FWD	N	Y	0	Y	Y	Y	Y	Y	25
E62	Terminal [C1] Extended Function	18: Speed limit REV	N	Y	0	Y	Y	Y	Y	Y	25
E63	Terminal [V2] Extended Function		N	Y	0	Y	Y	Y	Y	Y	25
E76	DC link bus voltage detection level	200 to 400V: 200Vclass series 400 to 800V: 400Vclass series	Y	Y	*6	Y	Y	Y	Y	Y	25
E98	Terminal [FWD] Function	59 (1059): Enable battery operation (BATRY)	N	Y	98	Y	Y	Y	Y	Y	18
E99	Terminal [REV] Function	110(1110): Servo lock gain selection (SLG2) 111(1111): Force to stop only by terminal (STOP-T) (111 = Active OFF, 1111 = Active ON)	N	Y	99	N	N	N	Y	N	18

*1 [FM1] and [FM2] for Asia (FRN_ _G1■-□A), EU (FRN_ _G1■-□E) and USA (FRN_ _G1■-□U) versions

*2 Terminals [X8] and [X9] not provided on Asia (FRN_ _G1■-□A), EU (FRN_ _G1■-□E) or USA (FRN_ _G1■-□U) version

*3 "8" for Asia (FRN_ _G1■-□A), EU (FRN_ _G1■-□E) and USA (FRN_ _G1■-□U) versions; "6" for other versions

*6 235V for 200V class series of inverters; 470V for 400V class series of inverters

Code	Name	Data setting range	Change when running	Data copying	Default setting	Drive control					Refer to page:
						V/f	PG V/f	w/o PG	w/ PG	Torque control	
C21	Pattern Operation Mode	0: Execute a single cycle of pattern operation 1: Execute a cycle of pattern operation repeatedly 2: Execute a single cycle of pattern operation and run at constant speed	N	Y	0	Y	Y	Y	Y	N	25
C22	Stage 1 Running Time	0.00 to 6000 s	Y	Y	0.00	Y	Y	Y	Y	N	26
C23	Stage 2 Running Time	0.00 to 6000 s	Y	Y	0.00	Y	Y	Y	Y	N	26
C24	Stage 3 Running Time	0.00 to 6000 s	Y	Y	0.00	Y	Y	Y	Y	N	26
C25	Stage 4 Running Time	0.00 to 6000 s	Y	Y	0.00	Y	Y	Y	Y	N	26
C26	Stage 5 Running Time	0.00 to 6000 s	Y	Y	0.00	Y	Y	Y	Y	N	26
C27	Stage 6 Running Time	0.00 to 6000 s	Y	Y	0.00	Y	Y	Y	Y	N	26
C28	Stage 7 Running Time	0.00 to 6000 s	Y	Y	0.00	Y	Y	Y	Y	N	26
C30	Frequency Command 2	10: Pattern operation	N	Y	2	Y	Y	Y	Y	N	17
C40	Terminal [C1] Range Selection	0: 4 to 20 mA 1: 0 to 20 mA	N	Y	0	Y	Y	Y	Y	Y	26
C82	Stage 1 Rotation Direction & Acceleration/Deceleration Time	1: Forward Acceleration Time 1 (F07)/Deceleration Time 1 (F08)	Y	Y	1	Y	Y	Y	Y	N	27
C83	Stage 2 Rotation Direction & Acceleration/Deceleration Time	2: Forward Acceleration Time 2 (E10)/Deceleration Time 2 (E11)	Y	Y	1	Y	Y	Y	Y	N	27
C84	Stage 3 Rotation Direction & Acceleration/Deceleration Time	3: Forward Acceleration Time 3 (E12)/Deceleration Time 3 (E13)	Y	Y	1	Y	Y	Y	Y	N	27
C85	Stage 4 Rotation Direction & Acceleration/Deceleration Time	4: Forward Acceleration Time 4 (E14)/Deceleration Time 4 (E15)	Y	Y	1	Y	Y	Y	Y	N	27
C86	Stage 5 Rotation Direction & Acceleration/Deceleration Time	11: Reverse Acceleration Time 1 (F07)/Deceleration Time 1 (F08)	Y	Y	1	Y	Y	Y	Y	N	27
C87	Stage 6 Rotation Direction & Acceleration/Deceleration Time	12: Reverse Acceleration Time 2 (E10)/Deceleration Time 2 (E11)	Y	Y	1	Y	Y	Y	Y	N	27
C88	Stage 7 Rotation Direction & Acceleration/Deceleration Time	13: Reverse Acceleration Time 3 (E12)/Deceleration Time 3 (E13) 14: Reverse Acceleration Time 4 (E14)/Deceleration Time 4 (E15)	Y	Y	1	Y	Y	Y	Y	N	27
P05	Motor 1 (Online tuning)	0: Disable 1: Enable	Y	Y	0	Y	N	N	N	N	29
H81	Light Alarm Selection 1	0000 to FFFF (hex.)	Y	Y	0	Y	Y	Y	Y	Y	29
H82	Light Alarm Selection 2	0000 to FFFF (hex.)	Y	Y	0	Y	Y	Y	Y	Y	29
A19	Motor 2 (Online tuning)	0: Disable 1: Enable	Y	Y	0	Y	N	N	N	N	29
b19	Motor 3 (Online tuning)	0: Disable 1: Enable	Y	Y	0	Y	N	N	N	N	29
r19	Motor 4 (Online tuning)	0: Disable 1: Enable	Y	Y	0	Y	N	N	N	N	29
A46	Speed Control 2 I (Integral time)	999: Disable integral action	Y	Y	0.100	N	Y	Y	Y	N	29
A47	(Feed forward gain)	0.00 to 99.99s	Y	Y	0.00	N	N	Y	Y	N	32
b46	Speed Control 3 I (Integral time)	999: Disable integral action	Y	Y	0.100	N	Y	Y	Y	N	29
b47	(Feed forward gain)	0.00 to 99.99s	Y	Y	0.00	N	N	Y	Y	N	32
r46	Speed Control 4 I (Integral time)	999: Disable integral action	Y	Y	0.100	N	Y	Y	Y	N	29
r47	(Feed forward gain)	0.00 to 99.99s	Y	Y	0.00	N	N	Y	Y	N	32
J96	Brake Signal (Speed condition selection)	0 to 31 ----- Bit 0: Criterion speed for brake-ON (0: Detected speed, 1: Reference speed) ----- Bit 1: Reserved. ----- Bit 2: Response for brake-OFF current (0: Slow response, 1: Quick response) ----- Bit 3: Criterion frequency for brake-ON (0: Stop frequency (F25), 1: Brake-ON frequency (J71)) ----- Bit 4: Output condition of brake signal (0: Independent of a run command ON/OFF 1: Only when a run command is OFF)	N	Y	0						9
d04	Speed Control 1 I (Integral time)	999: Disable integral action	Y	Y	0.100	N	Y	Y	Y	N	29
d05	(Feed forward gain)	0.00 to 99.99s	Y	Y	0.00	N	N	Y	Y	N	32

Code	Name	Data setting range	Change when running	Data copying	Default setting	Drive control					Refer to page:
						V/f	PG V/f	w/o PG	w/ PG	Torque control	
d12	Speed Control (Jogging) I (Integral time)	999: Disable integral action	Y	Y	0.100	N	Y	Y	Y	N	29
d23	PG Error Processing	0: Continue to run 1 1: Stop running with alarm 1 2: Stop running with alarm 2 3: Continue to run 2 4: Stop running with alarm 3 5: Stop running with alarm 4	N	Y	2	N	Y	Y	Y	N	32
d27	Servo lock (Gain switching time)	0.000 to 1.000s	Y	Y	0.000	N	N	N	Y	N	33
d28	(Gain 2)	0.00 to 10.00 times	Y	Y	0.10	N	N	N	Y	N	33
d35	Overspeed Detection Level	0 to 120% 999: Depends on setting of d32 or d33	Y	Y	999	N	Y	Y	Y	Y	34
d41	Application-defined Control	0: Disable (Ordinary control) 1: Enable (Constant peripheral speed control) 2: Enable (Simultaneous synchronization, without Z phase) 3: Enable (Standby synchronization) 4: Enable (Simultaneous synchronization, with Z phase)	N	Y	0	Y	Y	Y	Y	Y	35
d60	Command (Encoder pulse resolution)	0014 to 0E10 (hex.) (20 to 3600 pulses)	N	Y	0400 (1024)	N	Y	N	Y	N	36
d62	(Pulse count factor 1)	1 to 9999	Y	Y	1	Y	Y	Y	Y	Y	-
d63	(Pulse count factor 2)	1 to 9999	Y	Y	1	Y	Y	Y	Y	Y	-
d71	Synchronous Operation (Main speed regulator gain)	0.00 to 1.50 times	Y	Y	1.00	N	Y	N	Y	N	36
d72	(APR P gain)	0.00 to 200.00 times	Y	Y	15.00	N	Y	N	Y	N	36
d73	(APR positive output limiter)	20 to 200%, 999: No limiter	Y	Y	999	N	Y	N	Y	N	36
d74	(APR negative output limiter)	20 to 200%, 999: No limiter	Y	Y	999	N	Y	N	Y	N	36
d75	(Z phase alignment gain)	0.00 to 10.00 times	Y	Y	1.00	N	Y	N	Y	N	36
d76	(Synchronous offset angle)	0 to 359 degrees	Y	Y	0	N	Y	N	Y	N	36
d77	(Synchronization completion detection angle)	0 to 100 degrees	Y	Y	15	N	Y	N	Y	N	36
d78	(Excessive deviation detection range)	0 to 65535 (Display in units of 10 pulses) (For 10000 or more: Display of the upper four digits in units of 100 pulses)	Y	Y	65535 ^{*4}	N	Y	N	Y	N	36
d81	Reserved	0 or 1	Y	Y	1	-	-	-	-	-	-
d82	Magnetic Flux Weakening Control (Vector control without speed sensor)	0: Disable 1: Enable	Y	Y	1	N	N	N	N	Y	36
d83	Magnetic Flux Weakening Low Limiter (Vector control without speed sensor)	10 to 70%	Y	Y	40%	N	N	N	N	Y	36
d84	Reserved	0 to 20 dB	Y	Y	5 dB	-	-	-	-	-	-
d85	Reserved	0 to 200%	Y	Y	95%	-	-	-	-	-	-
d86	Acceleration/Deceleration filter time constant	0.000 to 5.000s	Y	Y	0.000	Y	N	N	N	N	36
d90	Magnetic Flux Level during Deceleration (Vector control)	100 to 300%	Y	Y	150%	N	N	Y	Y	N	36
d91	ACR P gain (Vector control)	0.00 to 2.00, 999	Y	Y	999	N	N	Y	Y	Y	36
d92	Reserved	0.00 to 3.00	Y	Y	0.00	-	-	-	-	-	-
d98	Reserved	0000 to FFFF (hex.)	Y	Y	0000	Y	Y	N	N	N	-
d99	Function Extension 1	0 to 31 ----- Bit 0: Reserved ----- Bit 1: Reserved ----- Bit 2: Reserved ----- Bit 3: JOG (Ready for jogging) via the communications link (0: Disable, 1: Enable) ----- Bit 4: Reserved	Y	Y	0	-	-	-	-	-	36

*4 The standard keypad displays 6553 on the LED monitor and lights the x10 LED.

(For USA (FRN__G1■-□U) version, the standard keypad is Multi-function keypad (TP-G1W-J1).)

Code	Name	Data setting range	Change when running	Data copying	Default setting	Drive control					Refer to page:
						V/f	PG V/f	w/o PG	w/ PG	Torque control	
U01	Customizable Logic: (Input 1)	16 (1016): Stage transition signal for pattern operation (TU)	N	Y	0	Y	Y	Y	Y	Y	21
U02	Step 1 (Input 2)	17 (1017): Cycle completion signal for pattern operation (TO)	N	Y	0	Y	Y	Y	Y	N	21
U06	Customizable Logic: (Input 1)	18 (1018): Pattern operation stage 1 (STG1)	N	Y	0	Y	Y	Y	Y	N	21
U07	Step 2 (Input 2)	19 (1019): Pattern operation stage 2 (STG2)	N	Y	0	Y	Y	Y	Y	N	21
U11	Customizable Logic: (Input 1)	20 (1020): Pattern operation stage 4 (STG4)	N	Y	0	Y	Y	Y	Y	N	21
U12	Step 3 (Input 2)	29 (1029): Synchronization completed (SY)	N	Y	0	Y	Y	Y	Y	N	21
U16	Customizable Logic: (Input 1)	77 (1077): Low DC link bus voltage (U-EDC)	N	Y	0	N	Y	N	Y	N	21
U17	Step 4 (Input 2)	79 (1079): Deceleration in momentary power failure (IPF2)	N	Y	0	Y	Y	Y	Y	Y	21
U21	Customizable Logic: (Input 1)	90 (1090): Alarm indication 1 (AL1)	N	Y	0	Y	Y	Y	Y	N	21
U22	Step 5 (Input 2)	91 (1091): Alarm indication 2 (AL2)	N	Y	0	Y	Y	Y	Y	Y	21
U26	Customizable Logic: (Input 1)	92 (1092): Alarm indication 4 (AL4)	N	Y	0	Y	Y	Y	Y	Y	21
U27	Step 6 (Input 2)	93 (1093): Alarm indication 8 (AL8)	N	Y	0	Y	Y	Y	Y	Y	21
U31	Customizable Logic: (Input 1)		N	Y	0						21
U32	Step 7 (Input 2)		N	Y	0						21
U36	Customizable Logic: (Input 1)		N	Y	0						21
U37	Step 8 (Input 2)		N	Y	0						21
U41	Customizable Logic: (Input 1)		N	Y	0						21
U42	Step 9 (Input 2)		N	Y	0						21
U46	Customizable Logic: (Input 1)		N	Y	0						21
U47	Step 10 (Input 2)		N	Y	0						21
U81	Customizable Logic Output Signal 1 (Function selection)	59 (1059): Enable battery operation (BATRY)	N	Y	100	Y	Y	Y	Y	Y	18
U82	Customizable Logic Output Signal 2	110(1110): Servo lock gain selection (SLG2)	N	Y	100	N	N	N	Y	N	18
U83	Customizable Logic Output Signal 3	11(1111): Force to stop only by terminal (STOP-T)	N	Y	100	Y	Y	Y	Y	Y	18
U84	Customizable Logic Output Signal 4	(111 = Active OFF, 1111 = Active ON)	N	Y	100						
U85	Customizable Logic Output Signal 5		N	Y	100						
y20	RS-485 Communication 2 (Protocol selection)	0: Modbus RTU protocol 1: FRENIC Loader protocol (SX protocol) 2: Fuji general-purpose inverter protocol	Y	Y	0	Y	Y	Y	Y	Y	37
y96	Reserved	0 or 1	Y	Y	0*5	-	-	-	-	-	

*5 These function codes are reserved for particular manufacturers. Unless otherwise specified, do not access these function codes.

Chapter 5-2 Details of Function Codes Added

F01, C30 Frequency Command 1, Frequency Command 2

F01 or C30 sets the command source that specifies reference frequency 1 or reference frequency 2, respectively.

Data for F01, C30	Function
10	Pattern operation

 For details, refer to the description of C21 (Pattern operation mode).

F29 Analog output [FMA]/[FM1] (Mode selection) *

F32 Analog output [FM2] (Mode selection) *

* [FM1] and [FM2] are for Asia (FRN_ _ _G1■-□A), EU (FRN_ _ _G1■-□E) and USA (FRN_ _ _G1■-□U) versions.

Versions except Asia (FRN_ _ _G1■-□A), EU (FRN_ _ _G1■-□E) and USA (FRN_ _ _G1■-□U) versions

■ Mode selection (F29)

F29 specifies the property of the output to terminal [FMA]. You need to set switch SW4 on the control printed circuit board (control PCB).

Data for F29	[FMA] output form	Position of slide switch SW4 mounted on the control PCB
2	Current (0 to +20 mA DC)	IO

Asia (FRN_ _ _G1■-□A), EU (FRN_ _ _G1■-□E) and USA (FRN_ _ _G1■-□U) versions

■ Mode selection (F29 and F32)

F29 and F32 specify the property of the output to terminals [FM1] and [FM2], respectively. You need to set the slide switches on the control printed circuit board (control PCB).

Output form	Terminal [FM1]		Terminal [FM2]	
	Data for F29	Position of slide switch SW4 on the control PCB	Data for F32	Position of slide switch SW6 on the control PCB
Current (0 to +20 mA DC)	2	IO1	2	IO2

F31 Analog Output [FMA]/[FM1] (Function) *

F35 Pulse Output [FMP] (Function) Analog Output [FM2] (Function) *

* [FM1] and [FM2] are for Asia (FRN_ _ _G1■-□A), EU (FRN_ _ _G1■-□E) and USA (FRN_ _ _G1■-□U) versions.

These function codes enable monitoring of deviation in angle in synchronous operation. For details about synchronous operation, refer to the PG Interface Card Instruction Manual.

Data for F31	[FMA]/[FM1] output	Function (Monitor the following)	Meter scale (Full scale at 100%)
Data for F35	[FMP]/[FM2] output		
17	Positional deviation in synchronous operation	Deviation in angle	0% to 50% to 100%, representing -180° to 0° to +180° of the deviation

E01 to E09 Terminal [X1] to [X9] Function
E01 to E07 Terminal [X1] to [X7] Function *

E98 Terminal [FWD] Function
E99 Terminal [REV] Function

U81 to U85 Customizable Logic Output Signal 1 to 5 (Function selection)

* Terminals [X8] and [X9] are not provided on Asia (FRN_ _ _G1■-□A), EU (FRN_ _ _G1■-□E) or USA (FRN_ _ _G1■-□U) version.

Function code data		Terminal commands assigned	Symbol	Drive control					Related function codes
Active ON	Active OFF			V /f	P G V /f	w /o P G	w / P G	To rqu e co ntr ol	
59	1059	Enable battery operation	BATRY	Y	Y	Y	Y	Y	
110	1110	Servo lock gain selection	SLG2	N	N	N	Y	N	
111	1111	Force to stop only by terminal	STOP-T	Y	Y	Y	Y	Y	

■ Enable battery operation -- **BATRY** (Function code data = 59)

Turning this terminal command ON cancels the undervoltage protection so that the inverter runs the motor with battery power under an undervoltage condition.

When **BATRY** is assigned to any digital input terminal, the inverter trips after recovery from power failure just as F14 = 1 regardless of F14 setting. When **BATRY** is ON, the main power down detection is disabled regardless of H72 setting.

Note Prerequisites for battery operation

- (1) The terminal command **BATRY** (data = 59) must be assigned to any digital input terminal.
- (2) A DC link bus voltage must be supplied from the battery to the main circuit (L1/R-L3/T or L2/S-L3/T) as shown in Figures A and B given below.
- (3) A regulated voltage (sine-wave or DC voltage) must be supplied to the auxiliary power supply (R0-T0).
- (4) For 200 V class series / 230V class series for USA of 37 kW / 60 HP or above and 400 V ones / 460V ones for USA of 75 kW / 125 HP or above, a regulated voltage (sine-wave) must be supplied to the auxiliary fan power supply (R1-T1) as shown in Figure B. The fan power supply connector must be configured for battery operation as shown in Figure C.
- (5) The **BATRY**-assigned terminal (data = 59) must be turned ON at the same moment as closing of MC2.

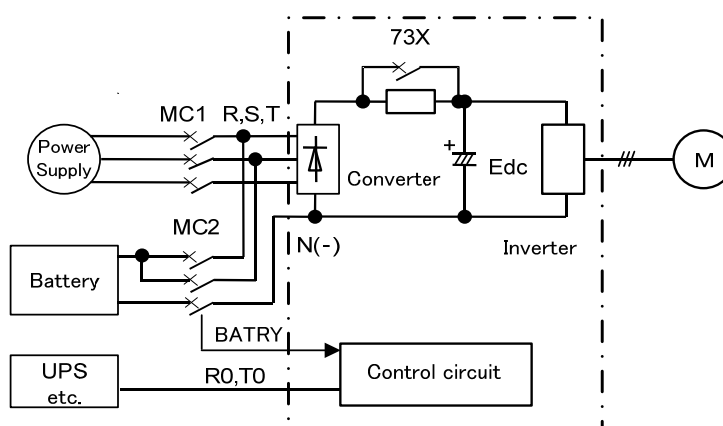

Figure A Connection Diagram
for 200 V Class Series of 30 kW
(230V Ones of 50HP for USA)
or Below
and 400 V Ones of 55 kW
(460V Ones of 100HP for USA)
or Below

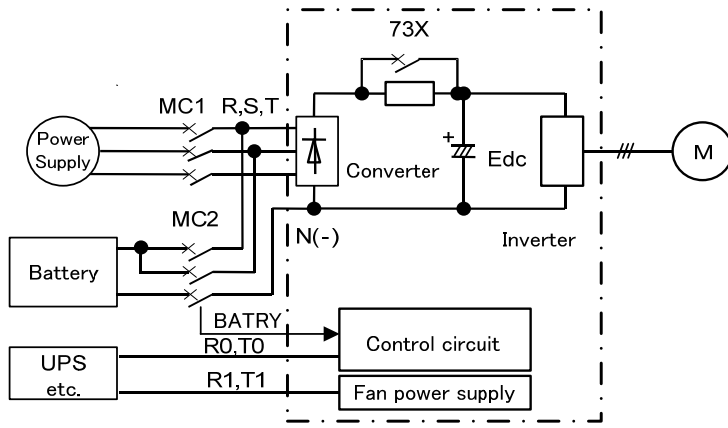

Figure B Connection Diagram
for 200 V Class Series of 37 kW
(230V Ones for USA of 60HP)
or Above
and 400 V Ones of 75 kW
(460V Ones for USA of 125HP)
or Above

Setting		
Usage	When not using R1 or T1 (Factory default)	When using R1 and T1 (BATRY operation)

Figure C Fan Power Supply Switching Connector

Note About battery operation (when **BATRY** is ON)

- (1) The undervoltage protective function ($\angle \angle$) is deactivated.
- (2) The inverter can run the motor even under an undervoltage condition.
- (3) The **RDY** ("Inverter ready to run") output signal is forcedly turned OFF.
- (4) The bypass circuit of the charging resistor comes to be closed (73X ON) after a delay of time T1 from when the **BATRY** is turned ON. Further, after a delay of time T2 (a maximum of 0.1 second), the battery operation starts. For the specifications of T1, see the table below.

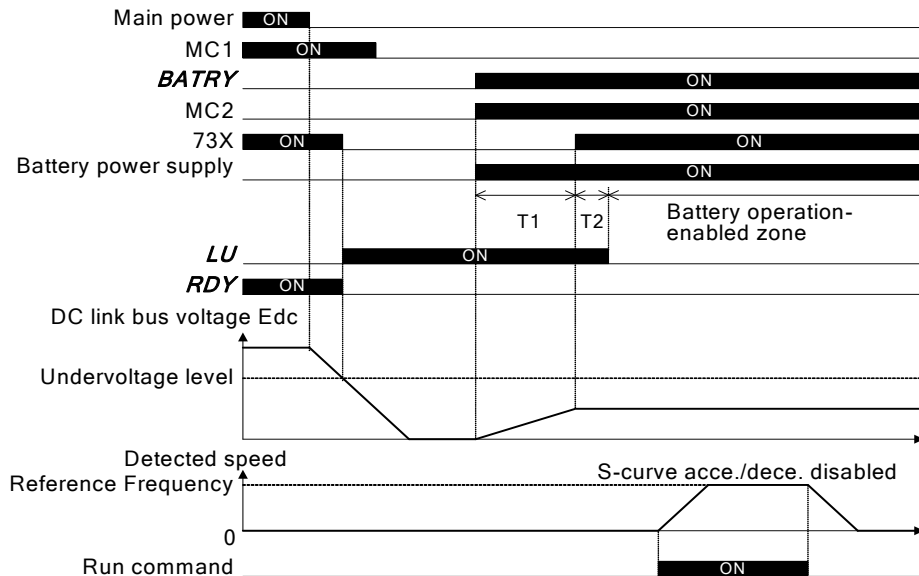

Battery Operation Timing Diagram

T1 from **BATRY** ON to 73X ON

Power condition	30 kW / 50 HP or below	37 kW / 60 HP or above
After the control power supply goes OFF, the battery power and control power are turned ON.	100 ms	500 ms
The control power remains ON or after a momentary power failure happens.	205 ms	

- (5) The S-curve acceleration/deceleration is disabled.
 (6) The battery operation speed can be calculated by the following formula.

$$\text{Reference speed (pre - ramp) during battery operation} \leq \frac{\text{Battery voltage} - 5[\text{V}]}{\sqrt{2} \times \text{Rated voltage}} \times \text{Rated speed} \times k$$

Where,

Battery voltage: 24 VDC or higher for 200 V class series / 230 V class series for USA
 48 VDC or higher for 400 V class series / 460 V class series for USA.

Rated speed : F04

Rated voltage : F05 (Motor rated voltage (V))

k: Safety coefficient (Less than 1, about 0.8)

Precautions

- (1) The battery power supply must be connected before or at the same moment as turning ON of **BATRY**.
- (2) As shown in the timing diagram above, battery operation is possible within the battery operation-enabled zone. There is a delay of "T1 + T2" after the **BATRY**, MC2, and battery power supply are turned ON.
- (3) The **BATRY** must not be turned ON when the voltage level is higher than the specified undervoltage level (that is, before the $\angle \angle'$ appears after a power failure). Turning the **BATRY** ON causes the bypass circuit (73X) of the charging resistor to stick to ON (closed).
- (4) During battery operation, driving with a heavy load must be avoided and the motor must run with no load or braking load condition. Low battery voltage cannot generate sufficient torque, causing the motor to stall.
- (5) The battery operation must be performed at a low speed. Be careful with the battery capacity.
 When a high voltage (e.g., 300 VDC for 200 V class series / 230 V class series for USA of inverters or 600 VDC for 400 V ones / 460 V ones for USA) is applied, not battery operation but normal operation must be performed.
- (6) In normal operation, the **BATRY** must be OFF. Turning the main power supply ON with the **BATRY** being ON could damage the rectifier diode because the 73X is ON.

■ Servo lock gain selection – **SLG2** (Function code data = 110)

When **SLG2** is turned ON, d28 (Servo lock gain 2) is selected. When **SLG2** is turned OFF, J97 (Servo lock gain) is selected.

( Function code J97, d27, d28)

■ Force to stop only by terminal – **STOP-T** (Function code data = 111)

When STOP-T is turned OFF, it operates force to stop. The command by communication is invalid. Only actual terminal command is effective. The operation is as same as STOP terminal.

E20 to E23 Terminal [Y1] to [Y4] Function
E24, E27 Terminal [Y5A/C] and [30A/B/C] Functions (Relay output)
U01, U02 ... U46, Customizable Logic: Step 1 to 10 (Input 1, Input 2)
U47

Function code data		Functions assigned	Symbol	Drive control				
Active ON	Active OFF			V/f	PG V/f	w/o PG	w/ PG	Torque control
16	1016	Stage transition signal for pattern operation	TU	Y	Y	Y	Y	N
17	1017	Cycle completion signal for pattern operation	TO	Y	Y	Y	Y	N
18	1018	Pattern operation stage 1	STG1	Y	Y	Y	Y	N
19	1019	Pattern operation stage 2	STG2	Y	Y	Y	Y	N
20	1020	Pattern operation stage 4	STG4	Y	Y	Y	Y	N
29	1029	Synchronization completed	SY	N	Y	N	Y	N
77	1077	Low DC link bus voltage	U-EDC	Y	Y	Y	Y	Y
79	1079	Deceleration in momentary power failure	IPF2	Y	Y	Y	Y	N
90	1090	Alarm indication 1	ALI	Y	Y	Y	Y	Y
91	1091	Alarm indication 2	AL2	Y	Y	Y	Y	Y
92	1092	Alarm indication 4	AL4	Y	Y	Y	Y	Y
93	1093	Alarm indication 8	AL8	Y	Y	Y	Y	Y
101	1101	Enable circuit failure detected	DECF	Y	Y	Y	Y	Y
102	1102	Enable input OFF	ENOFF	Y	Y	Y	Y	Y

■ Stage transition signal for pattern operation -- **TU** (Function code data = 16)

When the stage in a pattern operation is shifted, this output signal comes ON to issue a one-shot signal (100 ms).

■ Cycle completion signal for pattern operation -- **TO** (Function code data = 17)

Upon completion of all stages 1 through 7 in a pattern operation, this output signal comes ON to issue a one-shot signal (100 ms).

■ Pattern operation stage 1, 2, 4 -- **STG1, STG2, STG4** (Function code data = 18, 19, 20)

In a pattern operation, the combination of these output signals tell the current operation stage.

Pattern operation	Output terminal signals		
	STG1	STG2	STG3
Stage 1	ON	OFF	OFF
Stage 2	OFF	ON	OFF
Stage 3	ON	ON	OFF
Stage 4	OFF	OFF	ON
Stage 5	ON	OFF	ON
Stage 6	OFF	ON	ON
Stage 7	ON	ON	ON

■ Synchronization completed -- **SY** (Function code data = 29)

This output signal comes ON when the control target comes inside the synchronization completion detection angle in synchronous operation.

For details about synchronous operation, refer to the PG Interface Card Instruction Manual.

■ Low DC link bus voltage – **U-EDC** (Function code data = 77)

When DC link bus voltage becomes lower than E76 (DC link bus voltage detection level), **U-EDC** turns ON. When it becomes higher than E76, **U-EDC** turns OFF. (📖 Function code E76)

■ Deceleration in momentary power failure – **IPF2** (Function code data = 79)

In case F14 setting is 2 or 3, when DC link bus voltage becomes lower than H15 (continuous running level) and the inverter becomes continuous running condition, **IPF2** turns ON. When it becomes higher than H15 setting value + 10V, **IPF2** turns OFF.

In case F14 setting is 4 or 5, when DC link bus voltage becomes undervoltage alarm condition, **IPF2** turns ON. When it becomes higher than undervoltage alarm level + 10V, **IPF2** turns OFF.

(📖 Function code F14, H15)

■ Alarm content 1, 2, 4, 8 -- **ALI, AL2, AL4, AL8** (Function code data = 90, 91, 92, 93)

The combination of these output signals tells the activation status of the inverter protective function.

Alarm content (Inverter protective function)	Alarm code	Output terminals			
		ALI	AL2	AL4	AL8
Instantaneous overcurrent, Ground fault, Fuse blown	<i>OC1, OC2, OC3, EF, FUS</i>	ON	OFF	OFF	OFF
Overvoltage	<i>OU1, OU2, OU3</i>	OFF	ON	OFF	OFF
Undervoltage, Input phase loss	<i>LU, L in</i>	ON	ON	OFF	OFF
Overload of motor 1 through 4	<i>OL1, OL2, OL3, OL4</i>	OFF	OFF	ON	OFF
Inverter overload	<i>OLU</i>	ON	OFF	ON	OFF
Heat sink overheat, Inverter internal overheat	<i>OH1, OH3</i>	OFF	ON	ON	OFF
External alarm, Braking resistor overheat, Motor protection (PTC/NTC thermistor)	<i>OH2, dbH, OH4</i>	ON	ON	ON	OFF
Memory error, CPU error, Data saving error during undervoltage, Hardware error	<i>Er1, Er3, ErF, ErH</i>	OFF	OFF	OFF	ON
Keypad communications error, Option communications error	<i>Er2, Er4</i>	ON	OFF	OFF	ON
Option error	<i>Er5</i>	OFF	ON	OFF	ON
Charger circuit fault, Operation protection, Enable circuit failure, Braking transistor broken	<i>PbF, Er6, ECF, dbA</i>	ON	ON	OFF	ON
Tuning error, Output phase loss	<i>Er7, OPL</i>	OFF	OFF	ON	ON
RS-485 communications error	<i>Er8, ErP</i>	ON	OFF	ON	ON
Overspeed, PG wire break, Speed mismatch or excessive speed deviation, Excessive positioning deviation, Positioning control error	<i>OS, PG, ErE, dD, ErO</i>	OFF	ON	ON	ON
NTC wire break error, PID feedback wire break, Mock alarm	<i>nrb, CoF, Err</i>	ON	ON	ON	ON

Note: None of these output signals issues a signal when the inverter is running normally.

■ Enable circuit failure detected -- **DECF** (Function code data = 101)

This output signal comes ON when the inverter detects a failure of the Enable circuit(*1).

Configure a feedback circuit of the Enable input function as needed to feed back the transistor output of the **DECF**-assigned inverter to the reset input of the upper safety relay unit for turning the Enable command off and shutting down the inverter output. (Refer to Figure 9.10 "In the case of FRN__G1■-□□" in Section 9.6.6.)

■ Enable input OFF -- **EN OFF** (Function code data = 102)

This output signal comes ON when Enable inputs on [EN1] and [EN2] terminals are OFF (opened). See the table below.

*1: These signals do not assure detection of all of single failures. (Compliant with EN ISO13849-1 PL=d Cat. 3)

Logic Table for **DECF** and **EN OFF** Signals

Main power input L1/R, L2/S, L3/T	Enable input		Transistor output or Alarm relay output (for any error) *2		Output
	EN1-PLC	EN2-PLC	DECF	EN OFF	
OFF	x	x	OFF	OFF	Shut down (Safe Torque Off (STO) *3)
ON	OFF	OFF	OFF	ON	Shut down (Safe Torque Off (STO) *3)
	ON	ON	OFF	OFF	Wait for a run command
	ON	OFF	ON *4	OFF	Shut down (Safe Torque Off (STO) *3)
	OFF	ON	ON *4	OFF	Shut down (Safe Torque Off (STO) *3)

x: Independent of this state, the output is determined.

*2 To use these functions, it is necessary to assign **DECF/EN OFF** to digital output terminals (function codes E20 to E24 and E27, data = 101/102 or 1101/1102 (negative logic)).

*3 Output shutdown (Safe Torque Off) prescribed in IEC61800-5-2.

*4 If either one of these terminals are kept OFF for 50 ms or more, the inverter interprets it as a discrepancy, causing an alarm **EEF**. This alarm state can be cleared only by turning the inverter power off and on clears this alarm.

E49 Torque monitor (Polarity)

The polarity of calculated torque value in v/f control or the torque command value in vector control is normally + for driving and – for braking. However in the case of hoisting load, when the motor rotation direction changes from forward direction to reverse direction, the torque polarity also changes from driving to braking. If it monitors the torque data by FRENIC-Loader, we cannot take the expected data around zero speed because the polarity changes. If E49 is set to 0, the torque monitor data becomes + for forward/driving and reverse/braking, - for forward/braking and reverse/driving. We can monitor the continuous torque data around zero speed.

E49 data	Torque monitor polarity
0	Torque polarity (+ for forward/driving and reverse braking, - for forward/braking and reverse/driving)
1 (Factory setting)	+ for driving, - for braking

Related data is the followings. These data are displayed and submitted with polarity. Judge the meaning of polarity by E49 setting.

Monitor/ Output data	Setting	Related data
Remote keypad / Multi function keypad LED monitor	E43=8	Calculated torque value
	E43=23	Torque current
Remote keypad / Multi function keypad drive monitoring	3_04	Calculated torque value
Remote keypad / Multi function keypad alarm information	6_03	Calculated torque value at the time of the alarm occurrence. (Latest to 3 rd last)
OPC-G1-AIO	o71, o74=4	Output torque
Monitor code	M02	Torque command (Final command)
	M03	Torque current command (Final command)
	M07	Output torque
	M08	Torque current
	M28	Torque command on alarm. (Final command)
	M29	Torque current command on alarm. (Final command)
	M33	Output torque on alarm.
	W07	Torque operation value
	W24	Torque current
	X23	The latest information on alarm (Torque operation value)
	X63	The 1 st last information on alarm (Torque operation value)
	Z03	The 2 nd last information on alarm (Torque operation value)
	Z53	The 3 rd last information on alarm (Torque operation value)
	Z81	Output torque

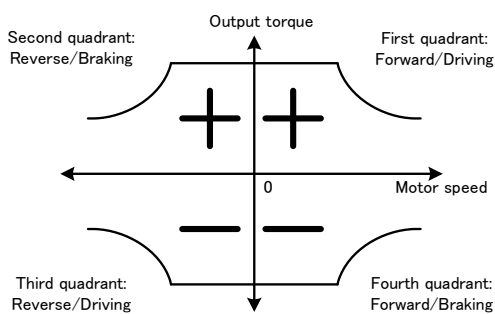

E49=0 ; Torque polarity

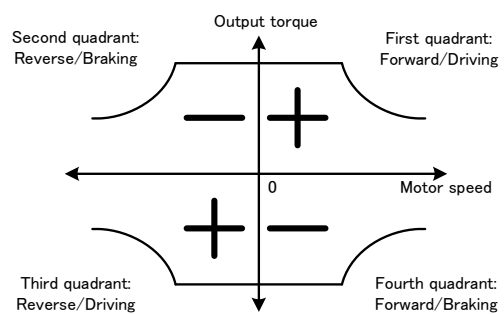

E49=1 : + for driving, - for braking

E61	Terminal [12] Extended Function
E62	Terminal [C1] Extended Function
E63	Terminal [V2] Extended Function

E61, E62, and E63 define the function of the terminals [12], [C1], and [V2], respectively.

As listed below, under torque control, analog inputs through terminals [12], [C1], and [V2] specify the motor speed limit values. To limit the motor speed to the maximum frequency (F02, A01, b01, r01), apply a full-scale analog input (maximum input).

It is recommended that this speed limit function be used together with d35 (Overspeed detection level).

Data for E61, E62, or E63	Input assigned to [12], [C1] and [V2]
17	Speed limit FWD
18	Speed limit REV

 **Note** Function codes C31 to C45 (Analog input adjustment) apply to these analog inputs.

E76 DC link bus voltage detection level

When DC link bus voltage becomes lower than E76 (DC link bus voltage detection level), *U-EDC* turns ON. Because the DC link bus voltage of the inverter is proportional to the input power supply voltage, this signal can detect the power supply voltage abnormality.

- Data setting range of E76 : 200 to 400V for 200V class series of inverters; 400 to 800V for 400V class series of inverters

C21 Pattern Operation Mode

Pattern operation allows the inverter to automatically run in accordance with the previously configured running time, rotation direction, acceleration/deceleration and reference frequency.

To use pattern operation, set F01 (Frequency command 1) at 10 (Pattern operation).

 For details about the configuration of pattern operation, refer to the description of C82 through C88 (Rotation direction & acceleration/deceleration time for stages 1 through 7).

The following pattern operation modes are available.

Data for C21	Pattern operation mode
0	Execute a single cycle of pattern operation and stop running
1	Execute a cycle of pattern operation repeatedly. Upon receipt of a stop command, the inverter immediately stops.
2	Execute a single cycle of pattern operation and then keep running at the current reference frequency

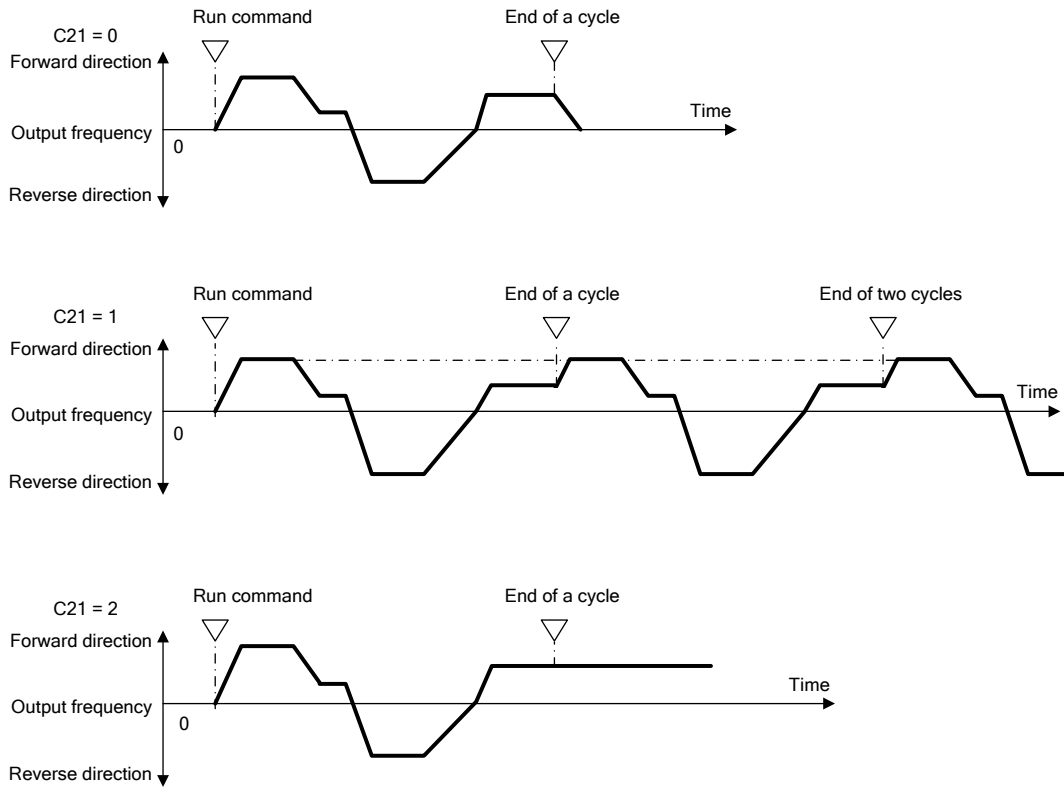

C22 to C28 Stage 1 to 7 Running Time

C22 to C28 specify the running time for stages 1 to 7, respectively.
 For stages not to be used, set the running time at 0.00. The inverter skips those stages and goes to the next stage.

C40 Terminal [C1] Range Selection

C40 specifies the range of the input current signal on terminal [C1] as listed below.

Data for C40	Range of Input Current Signal on Terminal [C1]
0	4 to 20 mA
1	0 to 20 mA

C82 to C88 Stage 1 to 7 Rotation Direction & Acceleration/Deceleration Time

C82 to C88 specify the rotation direction & acceleration/deceleration time for stages 1 to 7, respectively.

Data for C82 through C88	Rotation direction	Acceleration time	Deceleration time
1	Forward	F07 Acceleration time 1	F08 Deceleration time 1
2		E10 Acceleration time 2	E11 Deceleration time 2
3		E12 Acceleration time 3	E13 Deceleration time 3
4		E14 Acceleration time 4	E15 Deceleration time 4
11	Reverse	F07 Acceleration time 1	F08 Deceleration time 1
12		E10 Acceleration time 2	E11 Deceleration time 2
13		E12 Acceleration time 3	E13 Deceleration time 3
14		E14 Acceleration time 4	E15 Deceleration time 4

■ Pattern operation configuration example

C21 (Mode selection)	Stage No.	Running time		Rotation direction & Acceleration/deceleration time		Reference frequency
		Function code	Setting value	Function code	Setting value	
0	Stage 1	C22	60.0	C82	2	C05 Multi-frequency 1
	Stage 2	C23	100	C83	1	C06 Multi-frequency 2
	Stage 3	C24	65.5	C84	14	C07 Multi-frequency 3
	Stage 4	C25	55.0	C85	13	C08 Multi-frequency 4
	Stage 5	C26	50.0	C86	2	C09 Multi-frequency 5
	Stage 6	C27	72.0	C87	4	C10 Multi-frequency 6
	Stage 7	C28	35.0	C88	2	C11 Multi-frequency 7

As listed above, multi-frequency 1 to 7 are assigned to stages 1 to 7. Set the desired frequency to each of C05 to C11 beforehand.

The above configuration produces the pattern operation shown on the next page.

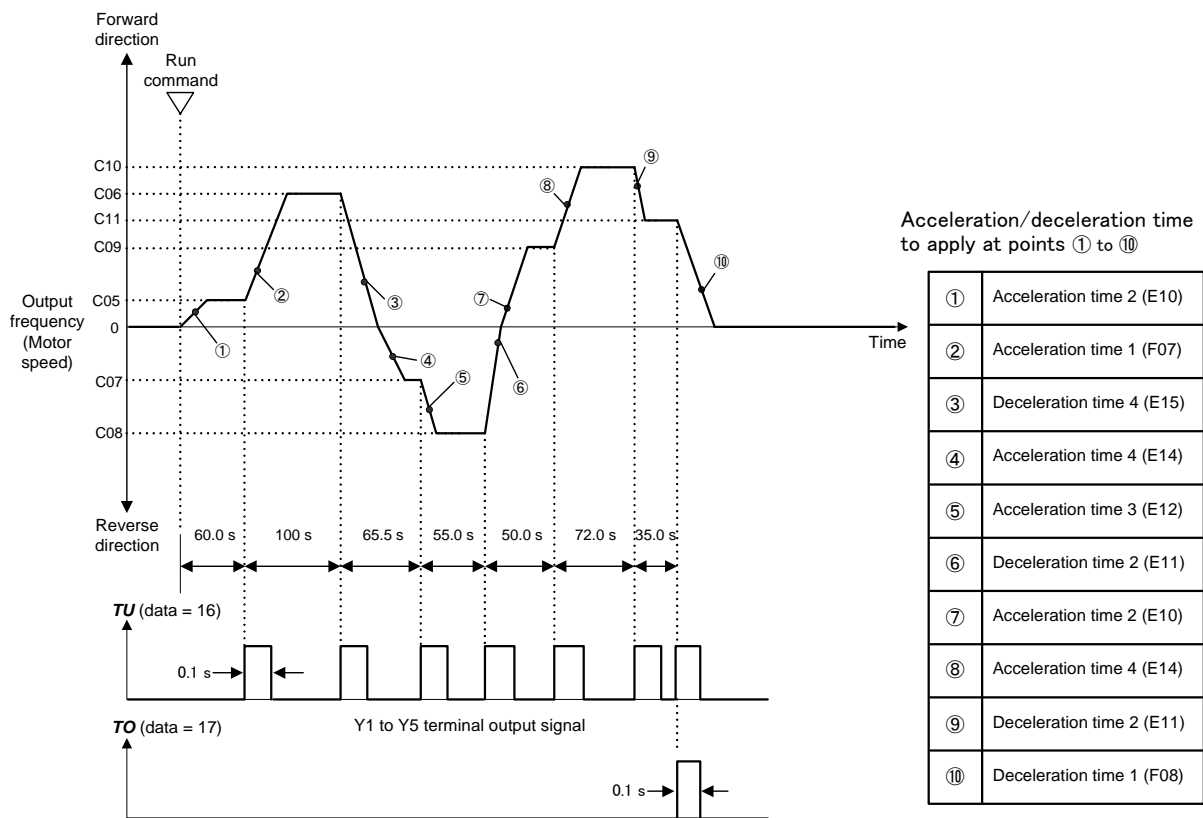

After completion of a cycle of pattern operation, the inverter decelerates to a stop in accordance with deceleration time 1 (F08).

- Starting/stopping the pattern operation with the **RUN** and **STOP** keys on the keypad or by opening/closing the control terminals

Taking the keypad as an example, pressing the **RUN** key starts the pattern operation and pressing the **STOP** key temporarily stops the progress of the stage. Pressing the **RUN** key again restarts the pattern operation from the stop point in accordance with the stage.

If the inverter stops due to an alarm, press the **PRG/RES** key to reset the inverter protective function and then press the **RUN** key. The progress of the stage restarts.

If the inverter needs to start from stage 1 (C22 and C82) halfway through a pattern operation, enter a stop command and then press the **PRG/RES** key.

After the inverter stops due to an alarm, if a pattern operation starting from stage 1 is required, press the **PRG/RES** key to reset the inverter protective function and then press the **PRG/RES** key again. The terminal command **RST** (assigned to an input terminal by setting "8" (Active ON) or "1008" (Active OFF) with any of E01 to E09) is functionally equivalent to the **PRG/RES** key.

- Tip** • Pattern operation can also be started by Run forward command (pressing the **RUN** key when F02 = 2 or turning the FWD terminal ON when F02 = 1) or Run reverse command (pressing the **REV** key when F02 = 3 or turning the REV terminal ON when F02 = 1). The rotation direction is determined by C82 to C88 regardless of whether the pattern operation is triggered by Run forward command or Run reverse command.
- When the FWD or REV terminal is used, the run command self-hold function does not work. Use an alternating switch.

⚠ CAUTION

If a pattern operation is started when C21 = 0 and the FWD (REV) terminal is ON, after completion of the last stage, the motor stops regardless of whether the FWD (REV) terminal remains ON.

Without turning the FWD (REV) terminal OFF, changing the setting of F01 or C30 or switching terminal command **H_z2/H_z1** ("Select frequency command 2/1") immediately restarts the motor in accordance with the reference frequency newly specified.

An accident or injuries could occur.

P05, A19 Motor 1/2/3/4 (Online tuning)
b19, r19

Long run under "Dynamic torque vector control" or "Slip compensation control" causes motor temperature change, varying the motor parameters. This changes the motor speed compensation amount, resulting in motor speed deviation from the initial rotating speed.

Enabling online tuning identifies motor parameters covering the motor temperature change to decrease the motor speed fluctuation.

To perform online tuning enabled with P05/A19/b19/r19, set P04 (Auto-tuning) to "2."

 Note: Online tuning can be performed only when F42 = 1 (Dynamic torque vector control) or when F42 = 2 (V/f control with slip compensation active) and F37 = 2 or 5 (Auto torque boost).

A46, b46, r46, d04, Speed Control 2, Speed Control 3, Speed Control 4, Speed Control 1,
d12 Speed Control (Jogging) (Integral time)

These function codes are used to configure the Automatic Speed Regulator (ASR) by selecting the PI controller or P controller.

Setting the function code data to "999" selects the P controller.

H81, H82 Light Alarm Selection 1 and 2

Assigning "1" to bit 2 of H82 defines excessive positioning deviation in synchronous operation as a light alarm.

For details about excessive positioning deviation, refer to the PG Interface Card Instruction Manual.

For details about definition of light alarms, refer to the FRENIC-MEGA Instruction Manual, Chapter 5.

Light Alarm Selection 2 (H82), Bit Assignment of Selectable Factors

Bit	Code	Content
2	<i>E_{rd}</i>	Positioning control error

 Even if a positioning control error is defined as a light alarm with H82, the error that occurred when the inverter was servo-locked does not cause a light alarm operation but trips the inverter.

J68 to J72 Brake Signal
J95, J96

These function codes are for the brake releasing/turning-on signals of vertical carrier machines.

It is possible to set the conditions of the brake releasing/turning-on signals (current, frequency or torque) so that a hoisted load does not fall down at the start or stop of the operation, or so that the load applied to the brake is reduced.

Releasing the Brake

When any of the inverter output current, output frequency, or torque command value exceeds the specified level of the brake signal (J68/J69/J95) for the period specified by J70 (Brake signal (Brake-OFF timer)), the inverter judges that required motor torque is generated and turns the signal **BRKS** ON for releasing the brake.

This prevents a hoisted load from falling down due to an insufficient torque when the brake is released.

Function code	Name	Data setting range	Remarks
J68	Brake-OFF current	0% to 300%:	
J69	Brake-OFF frequency/speed	0.0 to 25.0 Hz	Available only under V/f control.
J70	Brake-OFF timer	0.0 to 5.0 s	
J95	Brake-OFF torque	0% to 300%	Available only under vector control.

J96	Speed condition selection (Braking conditions)	Response for brake-OFF current (Bit 2) 0: Slow response (default) 1: Quick response	Specifies the response type for brake-OFF current detection. Selecting slow response inserts a detection filter into the current detection circuit so that the brake-OFF timing will be slightly behind the rising edge of the actual current. If the delay is not negligible with adjustments, select quick response.
-----	--	---	--

Turning the Brake ON

When the run command is OFF and the output frequency drops below the level specified by J71 (Brake signal (Brake-ON frequency/speed)) and stays below the level for the period specified by J72 (Brake signal (Brake-ON timer)), the inverter judges that the motor rotation is below a certain level and turns the signal **BRKS** OFF for activating the brake.

Under vector control, when the reference speed or the detected one drops below the level of the brake-ON frequency (specified by bit 3 of J96) and stays below the level for the period specified by J72 (Brake signal (Brake-ON timer)), the inverter judges that the motor rotation is below a certain level and turns the signal **BRKS** OFF for activating the brake.

This operation reduces the load applied to the brake, extending lifetime of the brake.

Function code	Name	Data setting range	Remarks
J71	Brake-ON frequency/speed	0.0 to 25.0 Hz	
J72	Brake-ON timer	0.0 to 5.0 s	
J96	Speed condition selection (Braking conditions)	Criteria of speed condition for brake-ON (Bit 0) 0: Detected speed 1: Reference speed	(Available only under vector control.) Specifies the criteria of speed to be used for brake-ON condition. When "Vector control without speed sensor" is selected, specify "Reference speed" (Bit 0 = 1).
		Criteria of frequency for brake-ON (Bit 3) 0: Stop frequency (F25) 1: Brake-ON frequency (J71)	(Available only under vector control.) Specifies the criteria of frequency to be used for brake-ON timing. If "Detected speed" and "Stop frequency" are selected (Bit 0 = 0 and Bit 3 = 0) to determine brake-ON timing, the brake may be applied after running at the stop frequency (F25) due to a speed error. If it is required that brake is applied during running at the stop frequency, select "Brake-ON frequency" (Bit 3 = 1) as criteria of frequency. When jogging or inching the motor for vertical conveyance, use J71 as brake-ON frequency.
		Turn-on condition of brake signal (Bit 4) 0: Independent of a run command ON/OFF 1: Only when a run command is OFF	(Available only under vector control.) Specifies whether to turn on a brake signal independent of a run command ON/OFF or only when a run command is OFF. When normal and reverse operations are switched, brake-ON conditions may be met in the vicinity of zero speed. For such a case, select "Only when a run command is OFF" (Bit 4 = 1).

- Operation time chart when Criteria of frequency for brake-ON (Bit 3) = 1 (Brake-ON frequency)

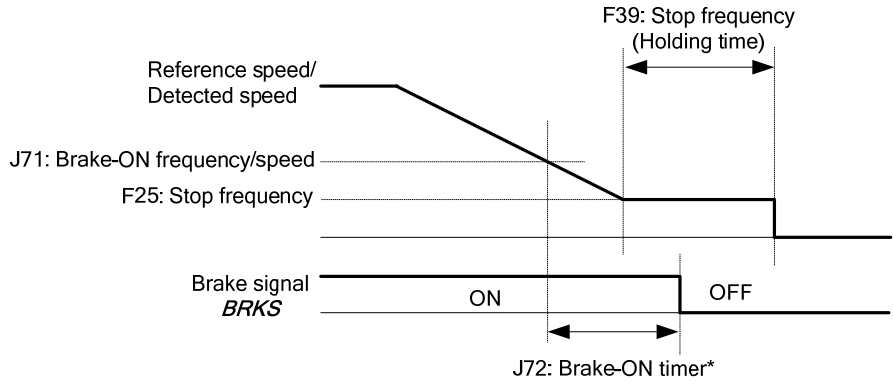

*If the inverter output is shut down during the timer period specified by J72, the inverter ignores the timer count and activates the brake.

- Operation time chart when Turn-on condition of brake signal (Bit 4) = 1 (Only when a run command is OFF)

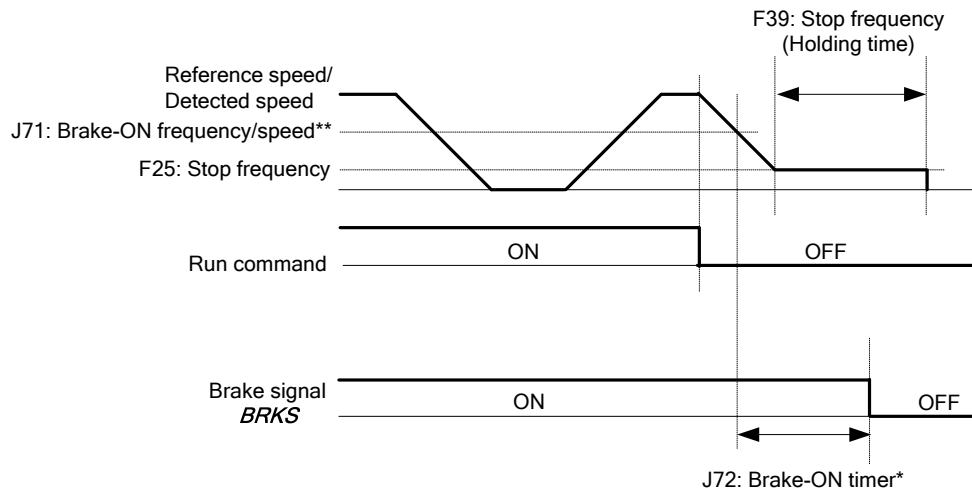

*If the inverter output is shut down during the timer period specified by J72, the inverter ignores the timer count and activates the brake.

**When bit 3 of J96 = 1

d05, A47 Speed control 1/2/3/4 (Feed forward gain)
b47, r47

The inverter operates the feed forward control that adds the acceleration torque calculated from the variation of speed command to torque command directly.

The PI control of ASR is feed back control and it makes the compensation operation against the result (actual speed detection value). Therefore it can control against the disturbance or the uncertain characteristic of controlled object also. However it becomes the follow-up control even if the variation of speed command is already-known.

It can calculate the torque command related to the already-known variation of speed command.

This is the function code that can make the feed forward control.

Setting range : 0.00 to 99.99s

When the moment of inertia is known, this function can be used effectively. Conceptually, as it is shown in the following figure, the follow-up speed against the actual speed command has clear difference between feed forward control valid and invalid. However, to get maximum effect, to adjust this function code setting and the PI control setting value of ASR is necessary.

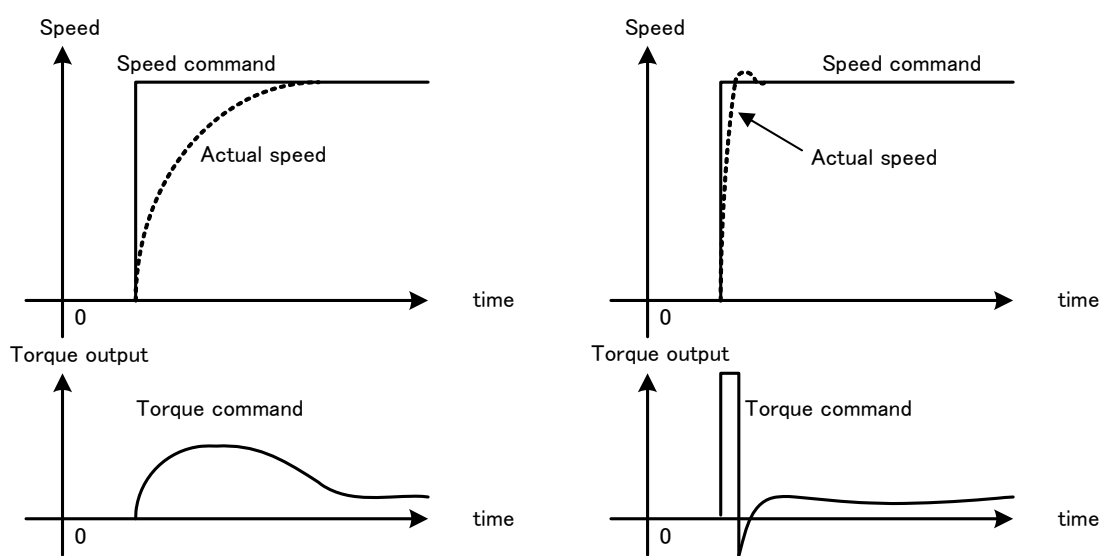

The above mentioned effect can be get by setting the P gain of ASR higher. However the response of the system becomes faster in this setting and there is a case that it effects negatively as generatong the vibration.

d23 PG Error Processing

d23 defines the detection condition and error processing to be applied when a PG error occurs.

- Data setting range: d23 = 0, 1, 2, 3, 4, 5

Data for d23	Function
0	Continue to run 1
1	Stop running with alarm 1
2	Stop running with alarm 2
3	Continue to run 2
4	Stop running with alarm 3
5	Stop running with alarm 4

If the speed regulator's deviation (between the reference speed and detected one) is out of the specified range (d21) for the specified period (d22), the inverter judges it as a PG error.

d23 defines the detection condition (and exception), processing after error detection, and hysteresis width as listed below.

Data for d23	Detection condition (and exception)	Processing after error detection	Hysteresis width for error detection
0	When the inverter cannot follow the reference speed (even after soft-starting) due to a heavy overload or similar, so that the detected speed is less than the reference speed, the inverter does not interpret this situation as a PG error.	The inverter outputs the PG error detected signal PG-ERR and continues to run.	Detection width = d21 × Maximum frequency, which is constant even if the speed command is above the base frequency (F04).
1		The inverter initiates a motor coast to stop, with the $\bar{E}-\bar{E}$ alarm. It also outputs the PG error detected signal PG-ERR .	
2	No exception.		
3	When the inverter cannot follow the reference speed (even after soft-starting) due to a heavy overload or similar, so that the detected speed is less than the reference speed, the inverter does not interpret this situation as a PG error.	The inverter outputs the PG error detected signal PG-ERR and continues to run.	If the speed command is below the base frequency (F04), detection width = d21 × Maximum frequency, which is constant. If it is above the base frequency, detection width = d21 × Speed command × Maximum frequency ÷ Base frequency (F04).
4		The inverter initiates a motor coast to stop, with the $\bar{E}-\bar{E}$ alarm. It also outputs the PG error detected signal PG-ERR .	
5	No exception.		

d27 Servo lock (Gain switching time)

d28 (Gain 2)

■ Servo lock (Gain) (J97) (Gain 2) (d28)

Set the position control regulator gain of servo lock function. It can adjust the stopping behavior and shaft holding torque in servo lock operation. It can select the gain value by servo lock gain selection terminal **SLG2**. It is possible to change selection during servo lock operation.

J97, d28	small ←————→ big
Stopping behavior	Slow response, Smooth ······ Fast response, Big hunting
Shaft holding torque	Holding torque small ······ Holding torque big

■ Servo lock (Gain switching time) (d27)

When it changes the gain value during servo lock operation by servo lock gain selection terminal **SLG2**, if the gain makes step change, there is a possibility to generate the vibration of servo lock control. Therefore this function code makes ramp control of servo lock gain and reduces the vibration.

d35 Overspeed Detection Level

d35 specifies the overspeed detection level under torque control by percentage of the maximum frequency (F03, A01, b01, r01).

If the following condition is satisfied, the inverter detects an overspeed state and issues an overspeed alarm $\mathcal{L}5$.

$$\text{Motor speed} \geq \text{Maximum frequency (F03/A01/b01/r01)} \times \text{d35}$$

Setting d35 data to "999" causes the inverter to issue an overspeed alarm $\mathcal{L}5$ if either of the following conventional conditions is satisfied.

$$\text{Motor speed} \geq \text{Maximum frequency (F03/A01/b01/r01)} \times (\text{d32 or d33}) \times 1.2$$

or

$$\text{Motor speed} \geq 200 \text{ Hz (vector control with speed sensor) or } 120 \text{ Hz (vector control without speed sensor)} \times (\text{d32 or d33}) \times 1.2$$

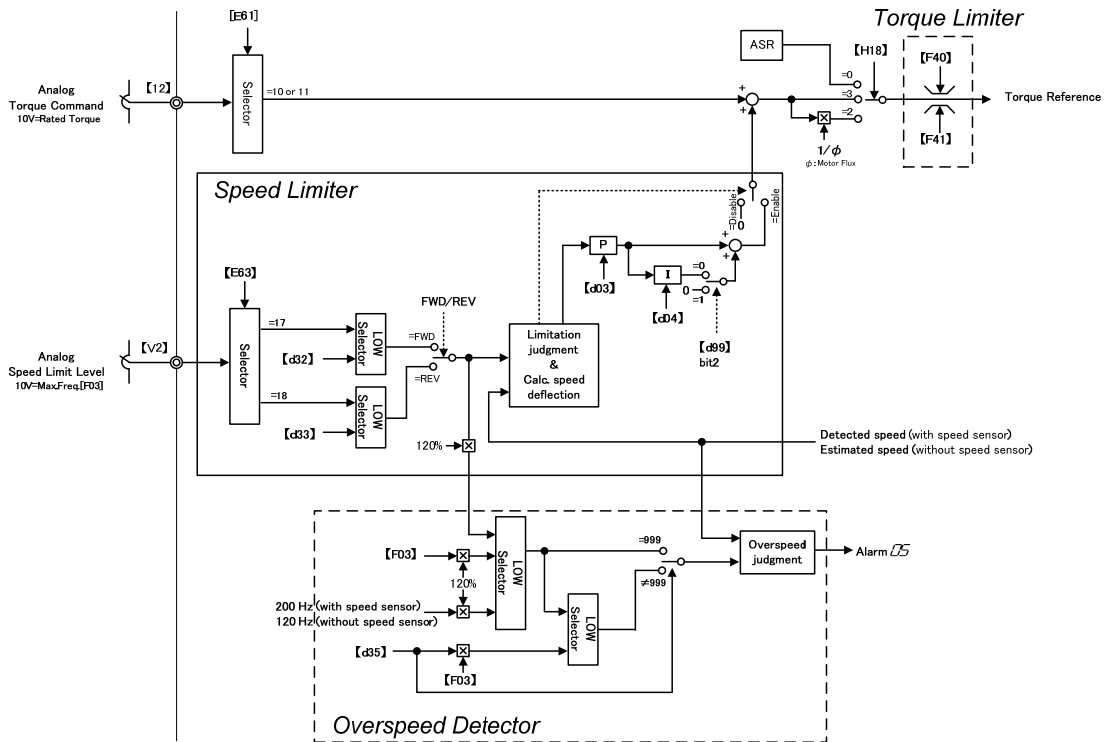

Block Diagram of Torque Control

Note Torque/Torque current command

It is possible to command torque/torque current from an analog voltage input (terminal [12] or [V2]) or analog current input (terminal [C1]), or via the communications link (function codes S02 and S03).

(To use the analog voltage/current input, function codes E61 (terminal [12]), E62 (terminal [C1]), and E63 (terminal [V2]) should be set to 10 or 11 as shown in the table below.

Input	Command form	Function codes	Setting specifications (Factory default)
Terminal [12] (-10 V to 10 V)	Torque command	E61=10	Motor rated torque $\pm 100\%$ / $\pm 10V$
	Torque current command	E61=11	Motor rated torque current $\pm 100\%$ / $\pm 10V$
Terminal [V2] (-10 V to 10 V)	Torque command	E63=10	Motor rated torque $\pm 100\%$ / $\pm 10V$
	Torque current command	E63=11	Motor rated torque current $\pm 100\%$ / $\pm 10V$
Terminal [C1] (0, 4 to 20 mA)	Torque command	E62=10	Motor rated torque 100% / 20 mA
	Torque current command	E62=11	Motor rated torque current 100% / 20 mA
S02 (-327.68 to 327.67%)	Torque command	-	Motor rated torque / $\pm 100.00\%$
S03 (-327.68 to 327.67%)	Torque current command	-	Motor rated torque current / $\pm 100.00\%$

Function codes C31 to C45 (Analog input adjustment) are applied to these analog inputs.

Speed limiter

The response of the speed limiter can be adjusted by using P gain and Integral time of the speed control as listed below.

Selected Motor	Function Codes	
	P gain	Integral time
M1	d03	d04
M2	A45	A46
M3	b45	b46
M4	r45	r46

d41 Application-Defined Control

d41 selects/deselects constant peripheral speed control or synchronous operation (simultaneous or standby synchronization).

Constant peripheral speed control suppresses an increase in peripheral speed (line speed) resulting from the increasing radius of the take-up roll in a winder system.

Synchronous operation drives two or more shafts of a conveyer while keeping their positions in synchronization. For details about synchronous control, refer to the PG Interface Card Instruction Manual.

■ Application-Defined Control (d41)

Data for d41	Function
0	Disable (Ordinary control)
1	Enable (Constant peripheral speed control)  Refer to the FRENIC-MEGA User's Manual, Chapter 5, Section 5.4.8 "d codes (Application functions 2)."
2	Enable (Simultaneous synchronization, without Z phase)
3	Enable (Standby synchronization)
4	Enable (Simultaneous synchronization, with Z phase)

d60 to d63 Command (Pulse Rate Input)
(Encoder pulse resolution, Filter time constant, Pulse count factor 1, Pulse count factor 2)

d71 to d78 Synchronous Operation

These function codes specify various parameters required for synchronous operation. For details, refer to the PG Interface Card Instruction Manual.

d82 Magnetic Flux Weakening Control (Vector control without speed sensor)

Setting d82 data to "1" (Enable) controls the motor magnetic flux in accordance with the torque command. When the torque command value is small, this control weakens the motor magnetic flux to improve the control stability.

d83 Magnetic Flux Weakening Low Limiter (Vector control without speed sensor)

d83 applies to the lower limit of the motor magnetic flux level when d82 = 1 (Enable). Decreasing the d83 setting too much may cause hunting, speed stagnation, and other problems. Use the default setting "40%" as long as there is no problem.

d86 Acceleration/Deceleration filter time constant

Set the filter time constant for the frequency output of acceleration/deceleration calculator. In case that the overshoot or under shoot is appeared in frequency arriving or stopping and it cause the problem against the machine, set this time constant. When big value is set, control stability becomes better, however the response becomes slower. This setting enables only in v/f control (F42 = 0 to 2). When the control mode is not v/f control, use the speed command filter for speed control (d01, A43, b43, r43). Setting range : 0.000: Disable, 0.001 to 5.000s

d90 Magnetic Flux Level during Deceleration (Vector control)

d90 specifies the magnetic flux level to be applied during deceleration under vector control by percentage of the rated motor magnetic flux (determined by P06/A20/b20/r20). d90 data takes effect only when H71 = 1 (Deceleration Characteristics enabled) and F42/A14/b14/r14 = 5 or 6 (Vector control with/without speed sensor). Increasing the d90 setting can reduce the deceleration time but increases the inverter output current and the motor temperature rise. In applications repeating frequent start/stop drive, an overload may apply to the inverter or motor. Adjust the d90 setting so that the inverter output current (RMS equivalent) comes to be smaller than the motor rated current. Use the default setting "150%" as long as there is no problem.

d91 ACR P gain (Vector control)

Vector control feeds back the motor output current to control a motor to follow the current command. This function specify the gain for the current control (ACR). Usually it must not be changed from the factory setting. When a winding has a large inductance, it should be set a large P gain to compensate it in general. When a winding has a small inductance, it should be set a small P gain to prevent OC(overcurrent) due to the overshoot of the current.

d99 Function Extension 1

Setting bit 3 of d99 to "1" enables a **JOG** ("Ready for jogging") given via the communications link.

 Other bits of d99 are reserved for particular manufacturer, so do not change the settings.

y20 selects the protocol of communication.

y20data	function
0	Modbus RTU protocol
1	FRENIC-Loader protocol (SX protocol)
2	Fuji general-purpose inverter protocol

Chapter 6

6.4 If an Alarm Code Appears on the LED Monitor

[34] *ECF* Enable circuit failure

Alarm code	Alarm name	Possible cause, what to check, and suggested measures
<i>ECF</i>	Enable circuit failure	(1) Contact failure of the interface printed circuit board (PCB). → Check that the interface PCB is firmly mounted in place. (Turning the inverter power off and on clears this alarm.)
		(2) Enable circuit logic error → Check that the two output levels of the safety switch or other safety device are not discrepant. (EN1/EN2 = High/High or Low/Low) (Turning the inverter power off and on clears this alarm.)

Chapter 9

9.2 Compliance with European Standards

The CE marking on Fuji products indicates that they comply with the essential requirements of the Electromagnetic Compatibility (EMC) Directive 2004/108/EC, Low Voltage Directive 2006/95/EC and Machinery Directive 2006/42/EC which are issued by the Council of the European Communities

The products comply with the following standards

	Basic type	EMC filter built-in type
Electromagnetic Compatibility	Depends upon a filter dedicated to Fuji inverters*	EN61800-3 : 2004 Immunity : Second environment (Industrial) Emission : Category C3
Electrical Safety	EN61800-5-1: 2007	
Functional Safety	EN954-1:1997, EN61800-5-2:2007 SIL 2, EN ISO 13849-1 :2008	
Stop function	Safe torque off (STO: acc.EN61800-5-2:2007)	
Response time	50 ms or less (delay time to "Safe torque off" from turning off either terminal [EN1] or [EN2])	
Safety integrity level	SIL 2	
PFH	1.7×10^{-9} (Probability of a dangerous random hardware failure per hour)	
Category	3 (EN ISO 13849-1:2008)	
Performance level	d (EN ISO 13849-1:2008)	

* If connected with an external EMC filter dedicated to Fuji inverters, the basic type of inverters that bear a CE marking but have no built-in EMC filter becomes compliant with these EMC Directives.

CAUTION

The EMC filter built-in type of the FRENIC-MEGA inverters is categorized as "Category C3" of the EN61800-3. It is not designed for use in a domestic environment. It may interfere with the operations of home appliances or office equipment due to noise emitted from it.

* To bring the inverter into compliance with Functional Safety Standard, it is necessary to bring it into compliance with European Standards EN61800-5-1 and EN61800-3.

9.6 Compliance with Functional Safety Standard

9.6.1 General

In FRENIC-MEGA series of inverters, opening the hardware circuit between terminals [EN1]-[PLC] or between terminals [EN2]-[PLC] stops the output transistor, coasting the motor to a stop. (EN1: Enable input 1, EN2: Enable input 2) This is the Safe Torque Off (STO) function prescribed in EN60204-1, Category 0 (Uncontrolled stop) and compliant with Functional Safety Standard.

Using the Safe Torque Off (STO) function eliminates the need of external safety circuit breakers while conventional inverters need those breakers to configure the Functional Safety Standard compliant safety system.

⚠ WARNING ⚠

- The output shutdown function of this inverter uses the Safe Torque Off (STO) function prescribed in IEC61800-5-2 so that it does not completely shut off the power supply to the motor electrically. Depending upon applications, therefore, additional measures are necessary for safety of end-users, e.g., brake function that locks the machinery and motor terminal protection that prevents possible electrical hazard(s).
- The output shutdown function does not completely shut off the power supply to the motor electrically. Before starting wiring or maintenance jobs, therefore, be sure to disconnect the input power to the inverter and wait at least five minutes for inverters with a capacity of 22 kW/40 HP or below, or at least ten minutes for inverters with a capacity of 30 kW/50 HP or above.

Enable terminals and peripheral circuit, and internal circuit configuration

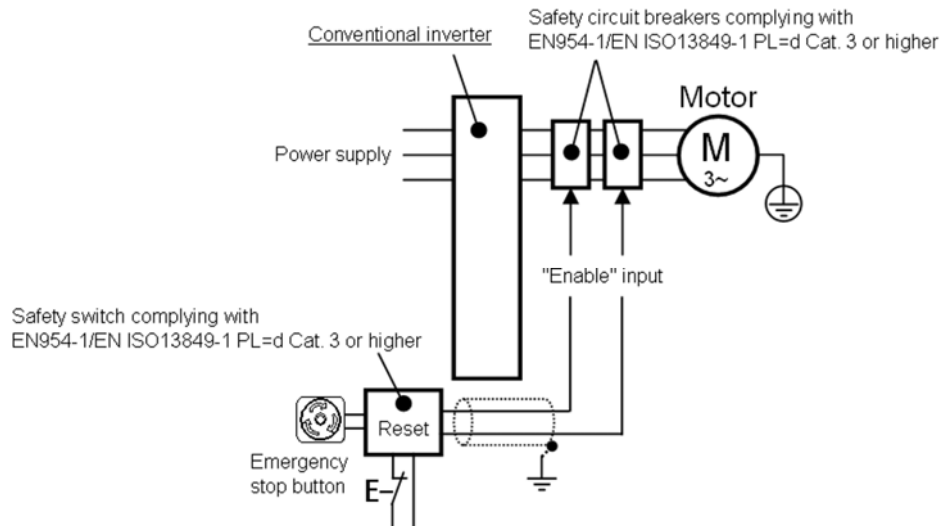
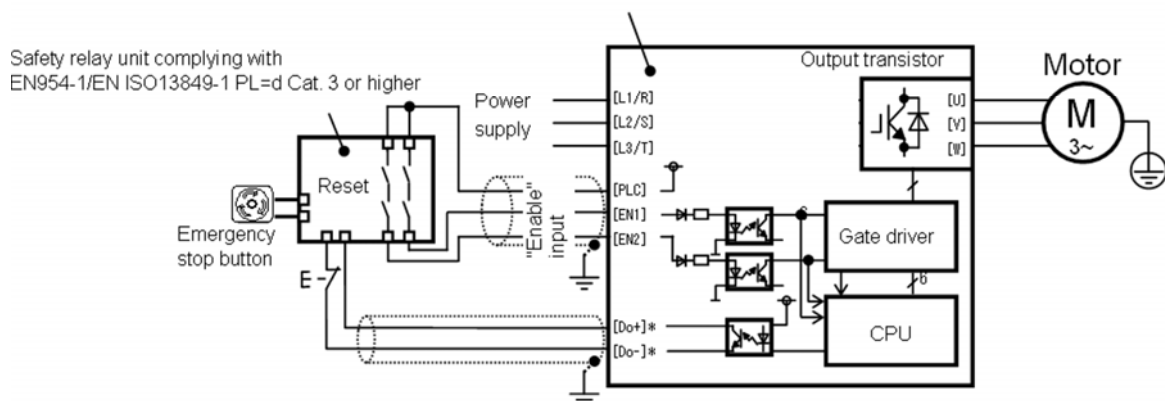

Figure 9.5 Conventional Inverters



FRENIC-MEGA (FRN_ _G1-□□)



*Transistor output terminals (e.g., [Y1]-[CMY], DECF(Function code data=1101), Refer to Section 9.6.6)

Figure 9.6 FRN_ _G1-□□

9.6.2 Notes for compliance to Functional Safety Standard

(1) Wiring for terminals [EN1] (Enable input 1) and [EN2] (Enable input 2)

- [EN1]/[EN2] and [PLC] are terminals prepared for connection of safety related wires; therefore, careful wiring should be performed to ensure that no short-circuit(s) can occur to these terminals.
- For opening and closing the hardware circuit between terminals [EN1]/[EN2] and [PLC], use safety approved components such as safety relays that comply with EN954-1/EN ISO13849-1 PL=d Cat. 3 or higher to ensure a complete shutoff.
- It is the responsibility of the machinery manufacturer to guarantee that a short-circuiting or other fault does not occur in wiring of external safety components between terminals [EN1]/[EN2] and [PLC].

Fault examples:

- Terminals [EN1]/[EN2] and [PLC] are short-circuited due to the wiring being caught in the door of the control panel so that a current continues to flow in terminal [EN1]/[EN2] although the safety component is OFF and therefore the safety function may NOT operate
- The wiring is in contact with any other wire so that a current continues to flow in terminal [EN1]/[EN2] and therefore the safety function may NOT operate

(2) Note for Safe Torque Off (STO)

- When configuring the product safety system with this Safe Torque Off (STO) function, make a risk assessment of not only the external equipment and wiring connected to terminals [EN1] and [EN2] (Enable input 1 and Enable input 2) but also the whole system including other equipment, devices and wiring against the product safety system required by the machinery manufacturer under the manufacturer's responsibility in order to confirm that the whole system conforms to the product safety system required by the machinery manufacturer.

In addition, as preventive maintenance, the machinery manufacturer must perform periodical inspections to check that the product safety system properly functions.

- To bring the inverter into compliance with Functional Safety Standard, it is necessary to install the inverter on a control panel with the enclosure rating of IP54 or above.
- To bring the inverter into compliance with Functional Safety Standard, it is necessary to bring it into compliance with European Standards EN61800-5-1 and EN61800-3.
- This Safe Torque Off (STO) function coasts the motor to a stop. When a mechanical brake is used to stop or hold the motor for the sake of the product safety system of whole system, do not use the inverter's control signals such as output from terminal [Y]. (Using control signals does not satisfy the safety standards because of software intervention.) Use safety relay units complying with EN954-1/EN ISO13849-1 PL=d Cat. 3 or higher to activate mechanical brakes.
- The safety shutdown circuit between terminal [EN1] and [EN2] input sections and inverter's output shutdown section is dual-configured (redundant circuit) so that an occurrence of a single fault does not detract the Safe Torque Off (STO).

If a single fault is detected in the safety shutdown circuit, the inverter coasts the motor to a stop even with the [EN1]-[PLC] and [EN2]-[PLC] states being ON, as well as outputting an alarm to external equipment. (Note that the alarm output function is not guaranteed to all of single faults. It is compliant with EN954-1/EN ISO13849-1 PL=d Cat. 3).

- The Safe Torque Off (STO) function does not completely shut off the power supply to the motor electrically. Before starting wiring or maintenance jobs, be sure to disconnect the input power to the inverter and wait at least 5 minutes.

(3) A test of Safe Torque Off (STO)

- In application where no regular activation of the Safe Torque Off (STO) function is guaranteed, check at least once a year that the Safe Torque Off (STO) function works correctly.

9.6.3 EN ISO13849-1 PL=d

European Standard EN ISO13849-1 PL=d (Safety of machinery–Safety related parts of control systems) prescribes the basic safety requirements for machinery categorized according to the requirement level. Category 3 represents the requirements that the machinery shall be designed with redundancy so that a single fault does not lead to the loss of the safety function. Table 9.3 shows an outline of the category levels and their safety requirements. (For detailed requirements, refer to EN ISO13849-1 PL=d.)

Table 9.3

Category	Summary of requirements	System behavior
B	SRP/CS and/or their protective equipment, as well as their components, shall be designed, constructed, selected, assembled and combined in accordance with relevant standards so that they can withstand the expected influence. Basic safety principles shall be used.	The occurrence of a fault can lead to the loss of the safety function.
1	Requirements of Category B shall apply. Well-tried components and well-tried safety principles shall be used.	The occurrence of a fault can lead to the loss of the safety function but the probability of occurrence is lower than for Category B.
2	Requirements of Category B and the use of well-tried safety principles shall apply. Safety function shall be checked at suitable intervals by the machine control system.	The occurrence of a fault can lead to the loss of the safety function between the checks. The loss of safety function is detected by the check.
3	Requirements of Category B and the use of well-tried safety principles shall apply. Safety-related parts shall be designed, so that <ul style="list-style-type: none"> - a single fault in any of these parts does not lead to the loss of the safety function, and - whenever reasonably practicable, the single fault is detected. 	When a single fault occurs, the safety function is always performed. Some, but not all, faults will be detected. Accumulation of undetected faults can lead to the loss of the safety function.
4	Requirements of Category B and the use of well-tried safety principles shall apply. Safety-related parts shall be designed, so that <ul style="list-style-type: none"> - a single fault in any of these parts does not lead to a loss of the safety function, and - the single fault is detected at or before the next demand upon the safety function, but that if this detection is not possible, an accumulation of undetected faults shall not lead to the loss of the safety function. 	When a single fault occurs, the safety function is always performed. Detection of accumulated faults reduces the probability of the loss of the safety function (high DC). The faults will be detected in time to prevent the loss of the safety function.

9.6.4 Inverter output state when Safe Torque Off (STO) is activated

Turning the emergency stop button ON turns EN1 and EN2 OFF, bringing the inverter into the Safe Torque Off (STO) state.

Figure 9.7 shows the timing scheme to apply when the emergency stop button is turned OFF with the inverter being stopped. Input to the EN1 and EN2 comes ON, making the inverter ready to run.

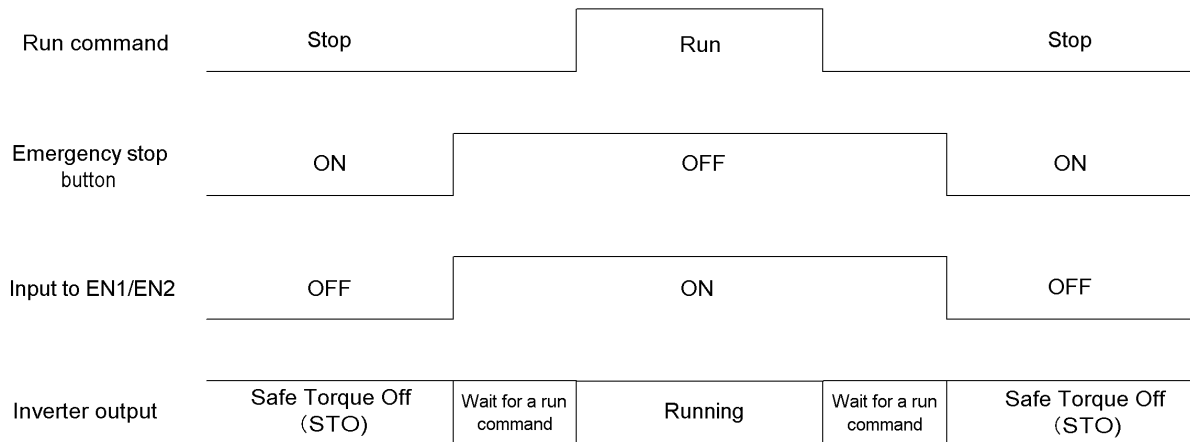

Figure 9.7 Inverter Output State when the Emergency Stop Button is Turned OFF with the Inverter being Stopped

Figure 9.8 shows the timing scheme to apply when the emergency stop button is turned ON with the inverter running. Input to the EN1 and EN2 goes OFF, bringing the inverter into the Safe Torque Off (STO) state and coasting the motor to a stop.

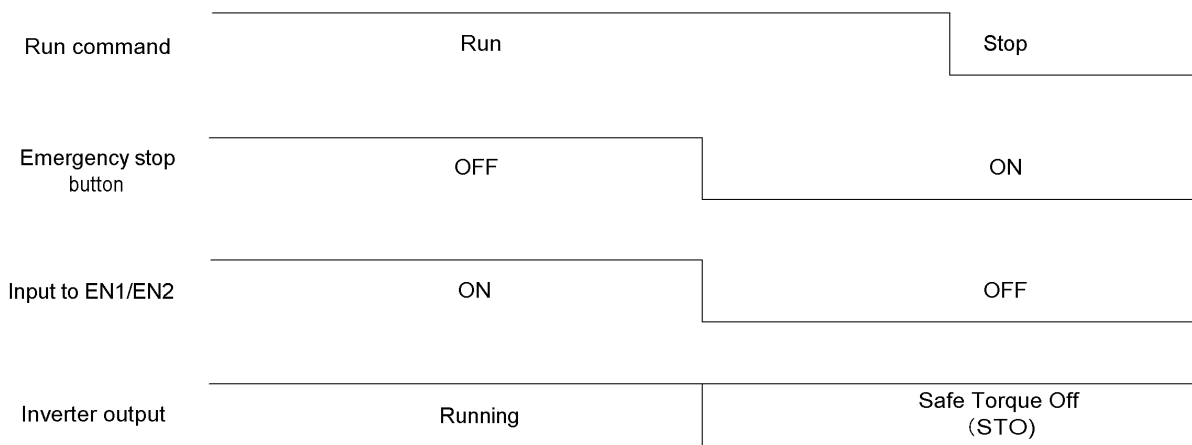

Figure 9.8 Inverter Output State when the Emergency Stop Button is Turned ON with the Inverter Running

9.6.5 ECF alarm (caused by logic discrepancy) and inverter output state

Figure 9.9 shows the timing scheme to apply when EN1 and EN2 inputs are not aligned so that an alarm ECF occurs.

Turning the emergency stop button ON turns EN1 and EN2 inputs OFF, which usually brings the inverter into the Safe Torque Off (STO) state. If the misalignment of the EN1 and EN2 inputs is within 50 ms, no alarm occurs; if it is more than 50 ms, the inverter interprets it as a logic discrepancy, outputting an alarm ECF . The alarm can be cleared by restarting the inverter.

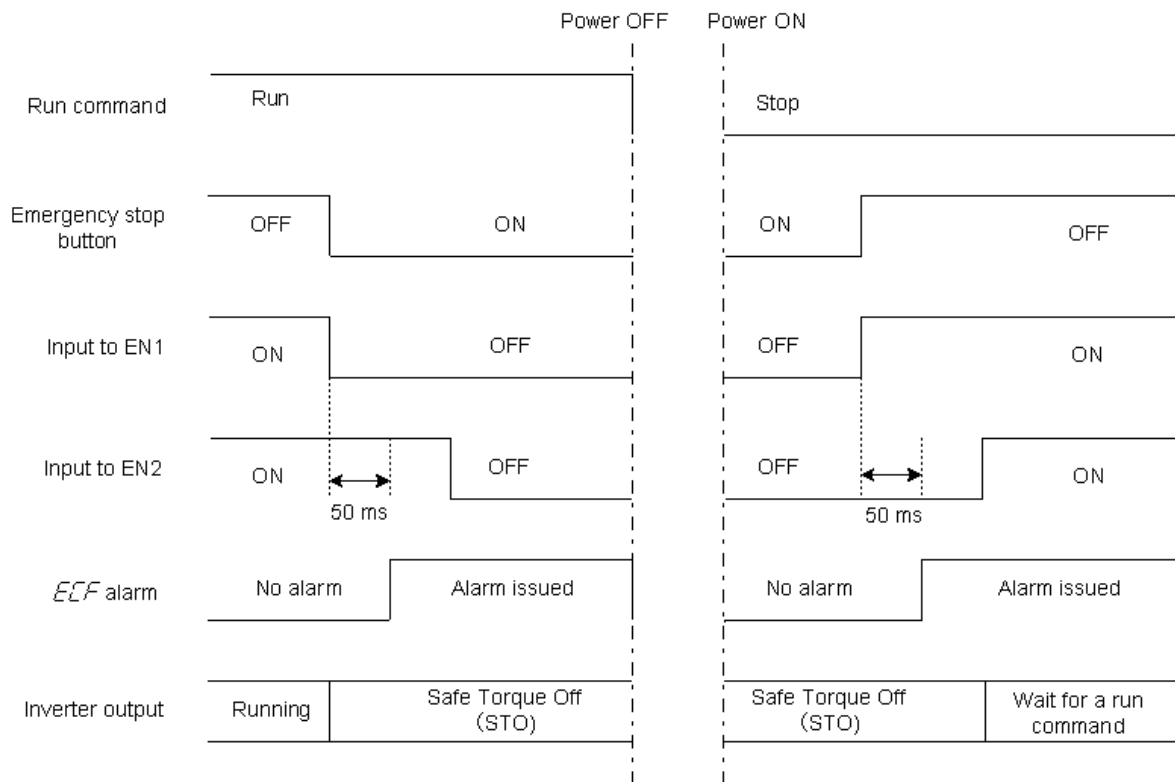

Figure 9.9 ECF Alarm (Caused by Logic Discrepancy) and Inverter Output State

9.6.6 Prevention of restarting

To prevent the inverter from restarting just by turning the emergency stop button OFF, configure the Enable input circuit as shown below. Figure 9.11 shows the timing scheme for prevention of restarting.

Assigning the **HLD** ("Enable 3-wire operation") to any digital input terminal and setting the E01 data to "6" sets up the **HLD** function at the [X1] terminal.

After the **FWD** comes ON with the **HLD** being ON, even turning the **FWD** OFF keeps the inverter running due to the **HLD**. Turning the emergency stop button ON under the condition causes the motor to coast to a stop. After that, turning the emergency stop button OFF no longer starts the inverter to run. To run the inverter, turn the **FWD** ON again.

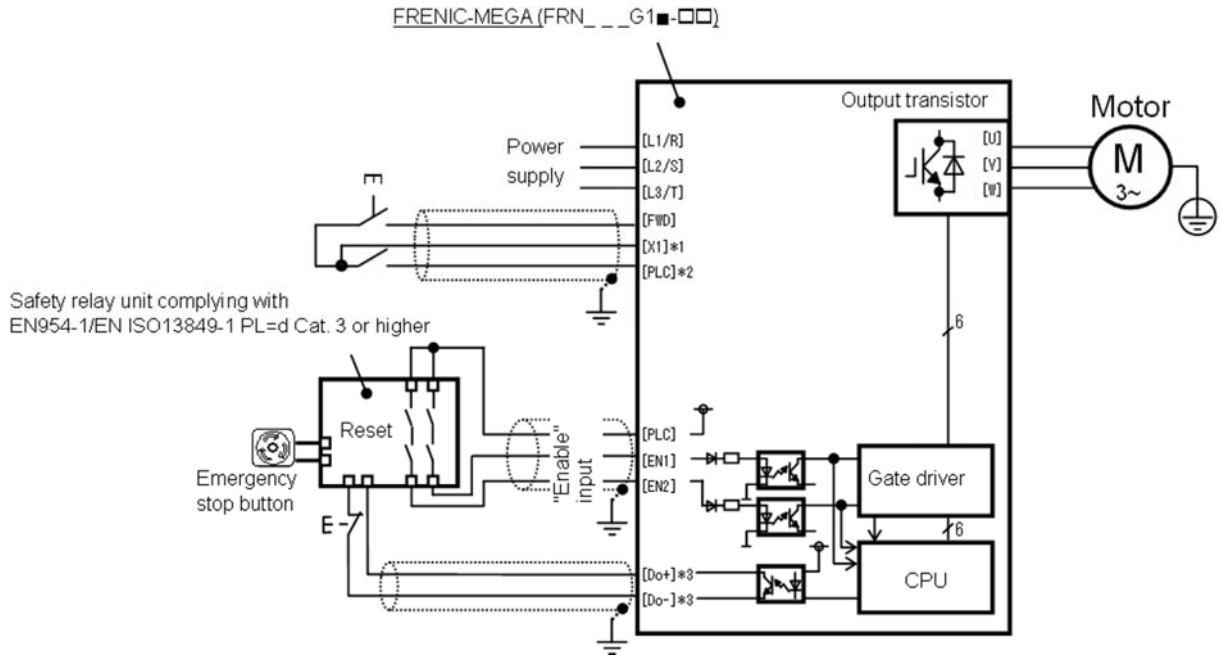

- *1 Digital input terminal (e.g., [X1])
- *2 If SW1 is in the SOURCE mode, [PLC] applies; if in the SINK mode, [CM] applies
- *3 Transistor output terminals (e.g., [Y1]-[CMY], DECF(Function code data=1101))

Figure 9.10 Connection Diagram and Internal Circuit Configuration

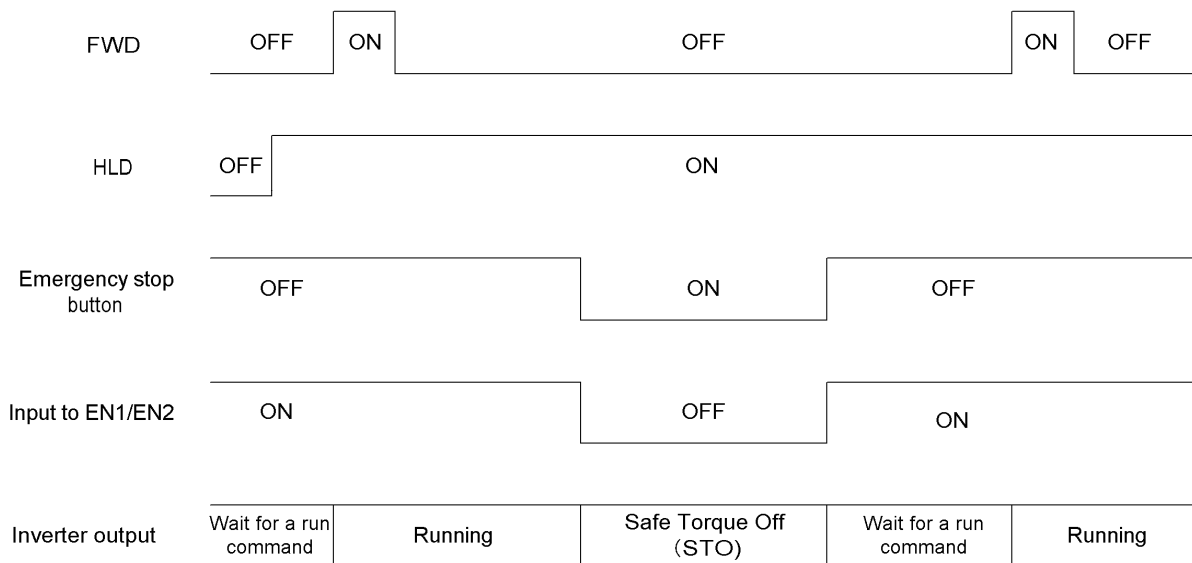

Figure 9.11 Prevention of Restarting

High Performance, Multifunction Inverter

FRENIC-MEGA

Instruction Manual
Supplement for Functional Safety Inverters

First Edition, May 2011
Second Edition, April 2013

Fuji Electric Co., Ltd.

The purpose of this instruction manual is to provide accurate information in handling, setting up and operating of the FRENIC-MEGA series of inverters. Please feel free to send your comments regarding any errors or omissions you may have found, or any suggestions you may have for generally improving the manual.

In no event will Fuji Electric Co., Ltd. be liable for any direct or indirect damages resulting from the application of the information in this manual.