

MONITOUCH

Hardware Specifications

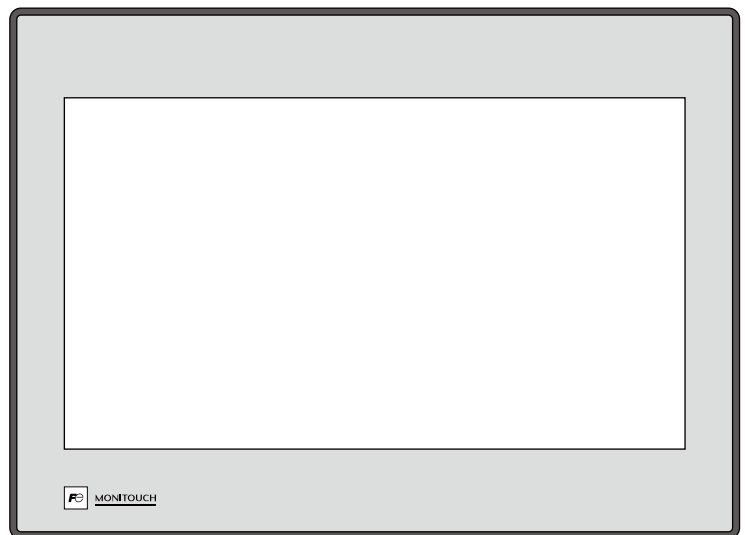

TS4000 Series

Record of Revisions

Reference numbers are shown at the bottom left corner on the back cover of each manual.

Printing Date	Reference No.	Revised Contents
July 2025	2026NE0	First edition

Preface

Thank you for selecting the MONITOUCH TS4000 series.

For correct use of the TS4000 series, you are requested to read through this manual to understand more about the product.

The manuals shown below are related manuals for the TS4000 series. Refer to them as necessary.

Manual Name	Contents	Reference No.
Smart Editor Reference Manual 1	Explains the functions and operation of the V10/V9/TS4000 series.	1210NE
Smart Editor Reference Manual 2		1211NE
Smart Editor Introductory Manual	Explains the installation procedure of Smart Editor, the process for configuring simple screen programs, as well as how to transfer a created screen program using Smart Editor.	1212NE
Smart Editor Training Manual Beginner's Guide	Explains the screen creation process using Smart Editor with examples in detail.	1213NE
Smart Editor Training Manual Practical Guide		1214NE
TS4000 Series Unit Operation / Local Mode / Error Screen Manual	Explains the operating procedures, Local mode screens, and error list for the TS4000 series.	1216NE
V10/V9/X1 Series Macro Reference	Provides an overview of macros of V-SFT version 6 and explains macro editor operations and macro command descriptions in detail.	1071NE
TS4000 Series Connection Manual 1	Explains the connection and communication parameters for the TS4000 series and controllers in detail.	2221NE
TS4000 Series Connection Manual 2		2222NE
TS4000 Series Connection Manual 3		2223NE
TS4000 Series Hardware Specifications	Explains hardware specifications and precautions when handling the TS4000 series.	2026NE

For details about controllers (PLCs, temperature controllers, etc.), refer to the manual issued by each controller manufacturer.

Notes:

1. This manual may not, in whole or in part, be printed or reproduced without the prior written consent of Hakko Electronics Co., Ltd.
2. The information in this manual is subject to change without prior notice.
3. Microsoft and Windows are registered trademarks of Microsoft Corporation in the United States and other countries.
4. All other company names or product names are trademarks or registered trademarks of their respective holders.
5. While the utmost care has been taken in the production of this manual, please contact your local sales representative regarding any doubts on the accuracy of explanations.

Notes on Safe Usage of MONITOUCH

In this manual, you will find various notes categorized under the following levels with the signal words "DANGER" and "CAUTION".



DANGER

Indicates an imminently hazardous situation which, if not avoided, will result in death or serious injury.



CAUTION

Indicates a potentially hazardous situation which, if not avoided, may result in minor or moderate injury and could cause property damage.

Note that there is a possibility that items listed with  CAUTION may have serious ramifications.



DANGER

- Never use the output signal of the TS4000 series for operations that may threaten human life or damage the system, such as signals used in case of emergency. Please design the system so that it can cope with a touch switch malfunction. A touch switch malfunction may result in machine accidents or damage.
- Turn off the power supply when you set up the unit, connect new cables, or perform maintenance or inspections. Otherwise, electrical shock or damage may occur.
- Never touch any terminals while the power is on. Otherwise, electrical shock may occur.
- The liquid crystal in the LCD panel is a hazardous substance. If the LCD panel is damaged, do not ingest the leaked liquid crystal. If leaked liquid crystal makes contact with skin or clothing, wash it away with soap and water.
- Never disassemble, recharge, deform by pressure, short-circuit, or reverse the polarity of the lithium battery, nor dispose of the lithium battery in fire. Failure to follow these conditions will lead to explosion or ignition.
- Never use a lithium battery that is deformed, leaking, or shows any other signs of abnormality. Failure to follow these conditions will lead to explosion or ignition.
- Switches on the screen are operable even when the screen has become dark due to a faulty backlight or when the backlight has reached the end of its service life. If the screen is dark and hard to see, do not touch the screen. Otherwise, unintended operations may occur resulting in machine accidents or damage.
- Tighten the mounting screws on the fixtures of the TS4000 series uniformly to a torque of 5.31 lbf-in (0.6 N-m). Excessive tightening may cause deformation, breakage, or malfunction of the touch switch, which may result in damage to the machine or an accident. Insufficient tightening may cause the unit to fall down, short-circuit, or malfunction.



CAUTION

- Check the appearance of the unit when it is unpacked. Do not use the unit if any damage or deformation is found. Failure to do so may lead to fire, damage, or malfunction.
- For use in a facility or as part of a system related to nuclear energy, aerospace, medical, traffic equipment, or mobile installations, consult your local sales representative.
- Operate (or store) the TS4000 series under the conditions indicated in this manual and related manuals. Failure to do so could cause fire, malfunction, physical damage or deterioration.
- Observe the following environmental restrictions on use and storage of the unit. Otherwise, fire or damage to the unit may result.
 - Avoid locations where there is a possibility that water, corrosive gas, flammable gas, solvents, grinding fluids, or cutting oil can come into contact with the unit.
 - Avoid high temperatures, high humidity, and outside weather conditions, such as wind, rain, or direct sunlight.
 - Avoid locations where excessive dust, salt, and metallic particles are present.
 - Avoid installing the unit in a location where vibrations or physical shocks may be transmitted.
- Protective functions may not function properly if a device is not used as specified by the manufacturer.
- Equipment must be correctly mounted so that the main terminal of the TS4000 series will not be touched inadvertently. Otherwise, an accident or electric shock may occur.
- Check periodically that terminal screws on the power supply terminal block and fixtures are firmly tightened. Loosened screws or nuts may result in fire or malfunction.
- Tighten the terminal screws on the power supply terminal block of the TS4000 series uniformly to a torque of 5.0 to 6.0 lbf-in (0.56 to 0.68 N-m). Improper tightening of screws may result in fire, malfunction, or other serious trouble.
- The TS4000 series has a glass screen. Do not drop or give physical shock to the unit. Otherwise, the screen may be damaged.
- Correctly connect cables to the terminals of the TS4000 series in accordance with the specified voltage and wattage. Overvoltage, overwattage, or incorrect cable connection could cause fire, malfunction, or damage to the unit.
- Always ground the TS4000 series. The FG terminal must be used exclusively for the TS4000 series with the level of grounding resistance less than 100 Ω . Otherwise, you may sustain an electric shock, a fire may occur, MONITOUCH may not recognize touch operations, and malfunctions may occur.

 **CAUTION**

- Prevent any conductive particles from entering into the TS4000 series unit. Failure to do so may lead to fire, damage, or malfunction.
- Do not attempt to repair, disassemble, or modify the TS4000 series unit yourself. Contact Hakko Electronics or the designated contractor for repairs.
- Do not repair, disassemble, or modify the TS4000 series unit. Hakko Electronics Co., Ltd. is not responsible for any damages resulting from repair, disassembly, or modification of the unit that was performed by an unauthorized person.
- Do not use sharp-pointed tools to press touch switches. Doing so may damage the display unit.
- Only technicians are authorized to set up the unit, connect cables, and perform maintenance and inspection.
- Lithium batteries contain combustible material such as lithium and organic solvents. Mishandling may cause heat, explosion, or ignition resulting in fire or injury. Read the related manuals carefully and correctly handle the lithium battery as instructed.
- Take safety precautions during operations such as changing settings when the unit is running, forced output, and starting and stopping the unit. Any misoperations may cause unexpected machine movement, resulting in machine accidents or damage.
- In facilities where the failure of the TS4000 series could lead to accidents that threaten human life or other serious damage, be sure that such facilities are equipped with adequate safeguards.
- When disposing of the TS4000 series unit, it must be treated as industrial waste.
- Before touching the TS4000 series unit, discharge static electricity from your body by touching grounded metal. Excessive static electricity may cause malfunction or trouble.
- If storage (USB flash drive) is removed while it is being accessed, the data in storage may become corrupted. Only remove storage after pressing the [Storage Removal] switch.
- Do not press two or more positions on the screen at the same time. If two or more positions are pressed at the same time, the switch located between the pressed positions may be activated.

[General Notes]

- Never bundle control cables or input/output cables with high-voltage and large-current carrying cables such as power supply cables. Keep control cables and input/output cables at least 200 mm away from high-voltage and large-current carrying cables. Otherwise, malfunction may occur due to noise.
- When using the TS4000 series in an environment where a source of high-frequency noise is present, it is recommended that the FG shielded cable (communication cable) be grounded at each end. However, when communication is unstable, select between grounding one or both ends, as permitted by the usage environment.
- Be sure to plug connectors and sockets of the TS4000 series in the correct orientation. Failure to do so may lead to damage or malfunction.
- Do not use thinners for cleaning because it may discolor the TS4000 series unit surface. Use commercially available alcohol.
- Clean the display area using a soft cloth to avoid scratching the surface.
- If a data receive error occurs when the TS4000 series unit and a counterpart unit (PLC, temperature controller, etc.) are started at the same time, read the manual of the counterpart unit to correctly resolve the error.
- Avoid discharging static electricity on the mounting panel of the TS4000 series unit. Discharging static electricity on the mounting panel may cause malfunction due to noise.
- The TS4000 series is identified as a class-A product in industrial environments. In the case of use in a domestic environment, the unit is likely to cause electromagnetic interference. Preventive measures should thereby be taken appropriately.
- The TS4000 series is equipped with a battery that contains lithium metal and therefore observance of transport regulations is necessary. Hakko Electronics ships TS4000 series units packed in accordance with transport regulations. If there is a need to transport a TS4000 series unit after it is once unpacked, transport the unit in accordance with the IATA Dangerous Goods Regulations, International Maritime Dangerous Goods (IMDG) Code, and transport regulations of the countries concerned. Ask your forwarding agent for details of transport regulations.

[Notes on the LCD]

Note that the following conditions may occur under normal circumstances.

- Avoid prolonged display of any fixed pattern. Due to the characteristic of liquid crystal displays, an afterimage may occur. If prolonged display of a fixed pattern is expected, use the backlight auto OFF function.
- The response time, brightness, and colors of the TS4000 series unit may be affected by the ambient temperature.
- Tiny spots (dark or luminescent) may appear on the display due to the characteristics of liquid crystal.
- Unevenness in brightness and flickering may occur depending on the screen display pattern due to the characteristics of liquid crystal.
- There are variations in brightness and color between units.
- Display colors may vary depending on the viewing angle because a converging lens is used in the backlight unit.

Contents

1	Product Outline	
1.1	Features	1-1
1.2	Models and Peripheral Equipment	1-2
1.2.1	MONITOUCH Models	1-2
1.2.2	Lineup	1-2
1.2.3	Peripheral Equipment	1-3
1.3	System Configuration	1-5
2	Specifications	
2.1	Specifications	2-1
2.1.1	General Specifications	2-1
2.1.2	Performance Specifications	2-3
2.1.3	Interface Specifications	2-4
2.1.4	Screen Configuration Environment	2-5
2.1.5	Display Function Specifications	2-5
2.1.6	Function Performance Specifications	2-6
2.2	External Dimensions and Panel Cut-out Dimensions	2-7
2.2.1	TS4150i	2-7
2.2.2	TS4120i	2-8
2.2.3	TS4100i	2-9
2.2.4	TS4070i	2-10
3	Names and Specifications of Components	
3.1	Names and Functions of Components	3-1
3.2	Specifications of Components	3-3
3.2.1	COM1	3-3
3.2.2	COM2/COM3	3-4
3.2.3	U-A	3-5
3.2.4	U-B	3-9
3.2.5	LAN	3-10
3.2.6	DIP Switches (DIPSW)	3-11
4	Installation	
4.1	Installation	4-1
4.1.1	Installation Procedure	4-1
4.1.2	Installation Conditions	4-2
4.2	Power Supply	4-4
4.2.1	Power Supply Terminal Block Specifications	4-4
4.2.2	Power Supply Cable Specifications	4-4
4.2.3	Power Supply Cable Connection	4-4
4.2.4	Grounding	4-5
4.3	Securing USB Cables	4-6
4.3.1	Securing Cables	4-6
4.4	Battery	4-7
4.4.1	Role of the Battery	4-7
4.4.2	Battery Replacement	4-7
4.4.3	EU Battery Regulation 2023/1542	4-10
4.4.4	"Perchlorate Best Management Practices" Regulations of California State Law, USA	4-10
4.4.5	Notes on Transport	4-10

5	Inspection and Maintenance	
5.1	Inspection and Maintenance.....	5-1
5.1.1	Daily Inspection.....	5-1
5.1.2	Periodical Inspection.....	5-1
5.2	Warranty Policy.....	5-2
5.2.1	Inquiries about Failure.....	5-2
5.2.2	Warranty Period.....	5-2
5.2.3	Free-of-charge Repair.....	5-2
5.2.4	Chargeable Repair.....	5-2

1 Product Outline

1.1 Features

1.2 Models and Peripheral Equipment

1.3 System Configuration

1.1 Features

The TS4000 series has the following features.

1. A programmable display unit that offers a maximum of 16.77 million display colors* and an LCD with an LED backlight. Three serial communication ports are provided by standard.
 - * For the TS4120i, it is 16.20 million display colors. This is for picture parts and 3D parts only. All other content is displayed using 65,536 colors.
2. LAN connector
LAN connectors (10BASE-T/100BASE-TX) are provided by standard on all models. The Auto-MDIX function is available.
3. USB port
The USB-A port (USB version 2.0) is provided by standard.
USB flash drives can be used as storage for saving screen programs and logging/alarm data, and transferring recipe data. The maximum capacity of a USB flash drive is 2 TB.
4. Scrolling function
Single screens can be registered at sizes higher than the resolution of the display unit and the scrolling function can be used to display each part of such screens.
According to screen configuration, this function can be used to display screens of sizes that extend in the horizontal and vertical directions.
In addition, navigation display is supported which allows users to instantly check the current display position.
5. Zoom in/out function
Double-tap a displayed screen to zoom in by a maximum of 200%.
This enables users to check parts that are small and difficult to see.
6. VNC server function
All models can be remotely monitored and operated from a computer or tablet.
It is also possible to perform only remote monitoring. In addition, direct operation of the TS4000 unit can be prohibited during remote operation.
Security is enhanced by supporting MAC address specification of client devices so that access from unspecified devices can be disabled.
7. Web Server function
Equipment can be monitored and operated by using the browser of such as a computer, tablet, or smartphone and displaying a Web screen program to access a MONITOUCH unit at the production site. Since a browser is used, there is no need for a dedicated client software. Simultaneous display and operation of any given screen by multiple clients is possible. The Web screen program to be displayed on the browser is created using the "Web Editor", which is a sub application provided within "Smart Editor".
8. VPN function
All models are equipped with a VPN function, enabling safe, simple and low-cost VPN communication. This function is useful such as for updating the screen program remotely, and enabling remote access with the VNC Server function or Web Server function.
9. Scheduler function
Predetermined operations (turning bits ON, executing macros, etc.) can be executed at a time set in advance, such as every week, every day, or a specified time.
Operations such as periodical saving of logging/alarm data can be scheduled easily.
10. Transition function
A variety of animation effects, such as slide in and box in, can be added to screen changes and to when overlaps are displayed or hidden.
11. Splash screen
A freely customizable splash screen can be displayed when MONITOUCH is starting up and when changing between the RUN and Local modes.
Images relevant to the usage environment, such as a company logo, a logo of the machine, or precautions, can be displayed.
12. TrueType font
TrueType fonts enable smoother character expression through anti-aliasing processing.
13. Configuration of settings in Local mode
The Local mode of the TS4000 unit can be used to easily check and change settings such as for the backlight, buzzer, and communication with connected devices.
Settings can be changed without editing the screen program using the screen configuration software.
14. Portrait orientation for TS4000 units
Mounting in a portrait orientation (90° left or 90° right) is possible to suit the installation environment of the TS4000 unit. Since screen editing in the screen configuration software also supports portrait orientations, screens can be configured for display in the target orientation.

1.2 Models and Peripheral Equipment

1.2.1 MONITOUCH Models

The model name consists of the following information.

TS4 0 i

Screen size	15: 15.6-inch widescreen, resolution (1366 × 768) 12: 12.1-inch widescreen, resolution (1280 × 800) 10: 10.1-inch widescreen, resolution (1024 × 600) 07: 7.0-inch widescreen, resolution (800 × 480)
-------------	--

1.2.2 Lineup

Model*1	Screen size	Resolution	Touch switch	Power supply	External interface	Conforming standards
TS4150i	15.6-inch widescreen	1366 × 768	Analog resistive film type	DC	Wired LAN: 1 channel	CE UKCA UL61010-1 UL61010-2-201 KC BIS
TS4120i	12.1-inch widescreen	1280 × 800			Serial communication port RS-422/485: 1 channel RS-232C: 1 channel*	
TS4100i	10.1-inch widescreen	1024 × 600			RS-485: 1 channel*	
TS4070i	7.0-inch widescreen	800 × 480			* RS-232C and RS-485 use the same connector.	
					USB-A (version 2.0): 1 channel USB mini-B (version 2.0): 1 channel	



*1 MONITOUCH has a black casing color and a silver surface sheet.

1.2.3 Peripheral Equipment

The following software and equipment are available as options for the TS4000 series.

Screen Configuration Software

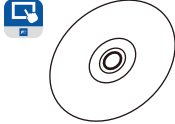
Application software for editing screen programs

Model	Description
SMED-DVD 	Screen configuration software "Smart Editor" DVD version Supported OS: Windows 10 (64-bit) / 11 (64-bit) The type of license differs depending on the model. SMED-DVD: 1 license SMED-DVD-Lxx: Multiple licenses (xx = number of licenses) SMED-DVD-SL: Site license SMED-DVD-VUP: Version updating DVD
SMED-DL 	Screen configuration software "Smart Editor" Download version Supported OS: Windows 10 (64-bit) / 11 (64-bit) The type of license differs depending on the model. SMED-DL: 1 license SMED-DL-Lxx: Multiple licenses (xx = number of licenses) SMED-DL-SL: Site license

Conversion Cables

These cables are used to convert the connector of controller connection cables for previous models such as of the V9, V8, TS2060, and V7 series into the connector for the TS4000 series.

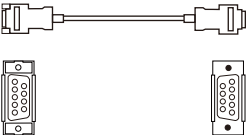
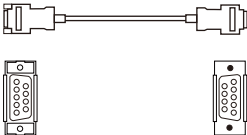
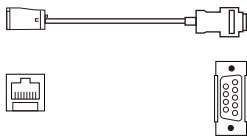
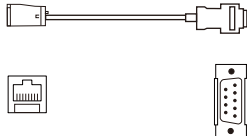
Model	Description																
D9-COM2 	RS-232C conversion cable for replacing V9/V8/TS2060 (D-sub 9-pin female to D-sub 9-pin female) 0.3 m <table border="1"> <tr> <td>Series</td> <td>: V9/V8/TS2060</td> <td>→</td> <td>TS4000</td> </tr> <tr> <td>Connection port</td> <td>: CN1</td> <td>→</td> <td>COM2</td> </tr> <tr> <td>Connector shape</td> <td>: D-sub 9-pin female</td> <td></td> <td>D-sub 9-pin female</td> </tr> <tr> <td>Signal level</td> <td>: RS-232C</td> <td></td> <td>RS-232C</td> </tr> </table>	Series	: V9/V8/TS2060	→	TS4000	Connection port	: CN1	→	COM2	Connector shape	: D-sub 9-pin female		D-sub 9-pin female	Signal level	: RS-232C		RS-232C
Series	: V9/V8/TS2060	→	TS4000														
Connection port	: CN1	→	COM2														
Connector shape	: D-sub 9-pin female		D-sub 9-pin female														
Signal level	: RS-232C		RS-232C														
D9-COM3 	RS-485 conversion cable for replacing V9/V8/TS2060 (D-sub 9-pin female to D-sub 9-pin female) 0.3 m <table border="1"> <tr> <td>Series</td> <td>: V9/V8/TS2060</td> <td>→</td> <td>TS4000</td> </tr> <tr> <td>Connection port</td> <td>: CN1</td> <td>→</td> <td>COM3</td> </tr> <tr> <td>Connector shape</td> <td>: D-sub 9-pin female</td> <td></td> <td>D-sub 9-pin female</td> </tr> <tr> <td>Signal level</td> <td>: RS-485</td> <td></td> <td>RS-485</td> </tr> </table>	Series	: V9/V8/TS2060	→	TS4000	Connection port	: CN1	→	COM3	Connector shape	: D-sub 9-pin female		D-sub 9-pin female	Signal level	: RS-485		RS-485
Series	: V9/V8/TS2060	→	TS4000														
Connection port	: CN1	→	COM3														
Connector shape	: D-sub 9-pin female		D-sub 9-pin female														
Signal level	: RS-485		RS-485														
MJF-COM2/COM3 	RS-232C/485 conversion cable for replacing V9/V8/TS2060 (RJ-45 female to D-sub 9-pin female) 0.3 m <table border="1"> <tr> <td>Series</td> <td>: V9/V8/TS2060</td> <td>→</td> <td>TS4000</td> </tr> <tr> <td>Connection port</td> <td>: MJ1/MJ2</td> <td>→</td> <td>COM2/COM3</td> </tr> <tr> <td>Connector shape</td> <td>: RJ-45 female</td> <td></td> <td>D-sub 9-pin female</td> </tr> <tr> <td>Signal level</td> <td>: RS-232C/485</td> <td></td> <td>RS-232C/RS-485</td> </tr> </table>	Series	: V9/V8/TS2060	→	TS4000	Connection port	: MJ1/MJ2	→	COM2/COM3	Connector shape	: RJ-45 female		D-sub 9-pin female	Signal level	: RS-232C/485		RS-232C/RS-485
Series	: V9/V8/TS2060	→	TS4000														
Connection port	: MJ1/MJ2	→	COM2/COM3														
Connector shape	: RJ-45 female		D-sub 9-pin female														
Signal level	: RS-232C/485		RS-232C/RS-485														
MJ2F-COM1 	RS-422/485 conversion cable for replacing V906/TS2060/V806/V706 (RJ-45 female to D-sub 9-pin male) 0.3 m <table border="1"> <tr> <td>Series</td> <td>: V906/TS2060/V806/V706</td> <td>→</td> <td>TS4000</td> </tr> <tr> <td>Connection port</td> <td>: MJ2</td> <td>→</td> <td>COM1</td> </tr> <tr> <td>Connector shape</td> <td>: RJ-45 female</td> <td></td> <td>D-sub 9-pin male</td> </tr> <tr> <td>Signal level</td> <td>: RS-422/485</td> <td></td> <td>RS-422/485</td> </tr> </table>	Series	: V906/TS2060/V806/V706	→	TS4000	Connection port	: MJ2	→	COM1	Connector shape	: RJ-45 female		D-sub 9-pin male	Signal level	: RS-422/485		RS-422/485
Series	: V906/TS2060/V806/V706	→	TS4000														
Connection port	: MJ2	→	COM1														
Connector shape	: RJ-45 female		D-sub 9-pin male														
Signal level	: RS-422/485		RS-422/485														

Waterproof Gaskets

Model	Description
TS4xx0-WP xx: 15/12/10/07 	<p>Waterproof gasket</p> <p>A waterproof gasket to make the front panel protection compliant with IP65.</p> <p>TS4150-WP: For the TS4150i TS4120-WP: For the TS4120i TS4100-WP: For the TS4100i TS4070-WP: For the TS4070i</p>

Protective Sheets

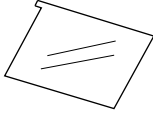
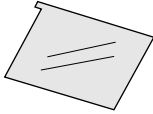
Model	Description
TS4xx0-GS xx: 15/12/10/07 	<p>Protective sheet: 5-piece set</p> <p>A sheet used for protecting the operation panel surface.</p> <p>TS4150-GS: For the TS4150i TS4120-GS: For the TS4120i TS4100-GS: For the TS4100i TS4070-GS: For the TS4070i</p>
TS4xx0-GSN10 xx: 15/12/10/07 	<p>Protective sheet (anti-glare type): 5-piece set</p> <p>A sheet used for protecting the operation panel surface. This sheet is colored light gray and the graininess of its surface prevents light reflection.</p> <p>TS4150-GSN10: For the TS4150i TS4120-GSN10: For the TS4120i TS4100-GSN10: For the TS4100i TS4070-GSN10: For the TS4070i</p>

Other Options

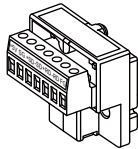
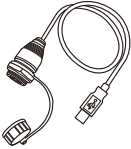
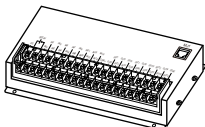
Model	Description
TS-BT 	<p>Replacement battery</p> <p>A replacement coin-type lithium battery for the TS4000 and TS2060 series.</p>
TC-D9 	<p>Terminal converter</p> <p>A converter for converting the COM1 port (D-sub 9-pin: RS-422/485) of the TS4000 series into a terminal block.</p>
UA-FR 	<p>USB-A panel face mounting cable, 1 m</p> <p>A cable for USB-A (master) that allows connection from the front of the panel.</p> <p>* Supported USB standard: USB version 2.0</p>
V-I/O 	<p>Serial extension I/O</p> <p>External I/O 16 inputs and 16 outputs</p> <p>* This can be used by connecting the optional conversion cable "MJF-COM2COM3" or "MJ2F-COM1" and the V-I/O accessory cable "CREC-CP".</p>

1.3 System Configuration

The following figure shows the possible system configurations.

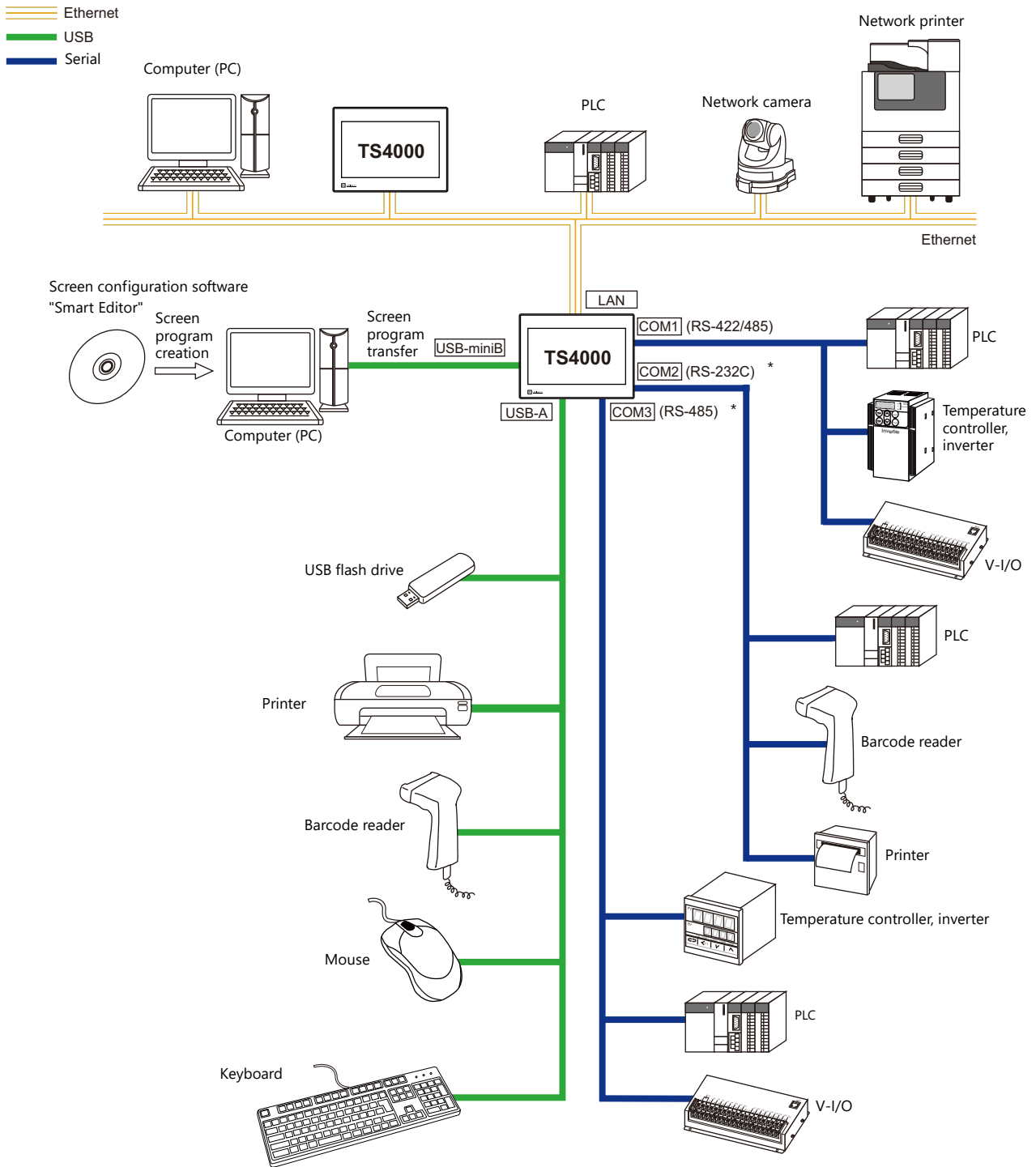

* The same connector is used for COM2 and COM3. Communication via COM2 (RS-232C) and via COM3 (RS-485) can take place at the same time.

2 Specifications

2.1 Specifications

2.2 External Dimensions and Panel Cut-out Dimensions

2.1 Specifications

2.1.1 General Specifications

Item		TS4150i	TS4120i	TS4100i	TS4070i
Conforming standards	CE	EMC directive (2014/30/EU) EN61000-6-2, EN61000-6-4 RoHS directive			
	UKCA	EMC directive (2016 No. 1091) EN61000-6-2, EN61000-6-4 RoHS directive			
	UL/cUL	UL61010-1/UL61010-2-201 (E313548) CAN/CSA-C22.2 No.61010-1, CAN/CSA-C22.2 No.61010-2-201			
	KC	Supported			
	BIS	Supported			
Power supply	Permissible voltage range	24 VDC \pm 10 %			
	Permissible momentary power failure	Within 1 ms			
	Power consumption (Max. rating)	12 W or less	11 W or less	10 W or less	8 W or less
	Rush current	20 A or less, 4.0 ms (ambient temperature at 25 °C)			
	Withstand voltage	DC external terminals to FG: 500 VAC for 1 minute			
Insulation resistance	DC external terminals to FG: At least 10 M Ω at 500 VDC				
Physical environment	Operational ambient temperature	0 °C to +50 °C ^{*1}			
	Storage ambient temperature	-10 °C to +60 °C ^{*1}			
	Operational ambient humidity	85 % RH or less (without dew condensation) ^{*1}			
	Storage ambient humidity	85 % RH or less (without dew condensation) ^{*1}			
	Altitude	2000 m or less			
	Atmosphere	No corrosive gas, no excessive dust, and no conductive dust			
	Overvoltage category ^{*2}	Category II			
Pollution degree ^{*3}	Pollution degree 2				
Mechanical working conditions	Vibration resistance	JIS B 3502 (IEC61131-2) compliant Vibration frequency: 5 to 9 Hz, Half-amplitude: 3.5 mm Vibration frequency: 9 to 150 Hz, Constant acceleration: 9.8 m/s ² (1 G) X, Y, Z: 3 directions (10 times each)			
	Shock resistance	JIS B 3502 (IEC61131-2) compliant Peak acceleration: 147 m/s ² (15 G) X, Y, Z: 3 directions, 3 times each (18 times in total)			
Electrical working conditions	Noise resistance	Noise voltage: 1000 Vp-p, Pulse width: 1 μ s, Rising time: 1 ns (Measured using a noise simulator)			
	Static electricity discharge resistance	Compliant with IEC61000-4-2, Contact: 6 kV, Air: 8 kV			
Mounting specifications	Grounding	Less than 100 Ω , FG/SG separated			
	Protection structure	Front ^{*4}	When waterproof gasket "TS4xx0-WP" is installed: Compliant with IP65 ^{*5, *6} When waterproof gasket "TS4xx0-WP" is not installed: Compliant with IP40		
		Back	Compliant with IP20		
	Cooling system	Natural cooling			
	Mounting method	Inserted in a mounting panel			
Mounting panel thickness	1.5 to 5.0 mm ^{*7}				
Weight		Approx. 2.3 kg	Approx. 1.5 kg	Approx. 1.1 kg	Approx. 0.6 kg
Dimensions	External dimensions (W \times H \times D)	402.8 \times 256.8 \times 48.0 mm	303.8 \times 223.8 \times 48.0 mm	263.8 \times 191.8 \times 38.0 mm	198.8 \times 141.8 \times 38.0 mm
	Panel cut-out dimensions (W \times H)	393.0 $^{+0.5}_{-0}$ \times 249.0 $^{+0.5}_{-0}$ mm	294.0 $^{+0.5}_{-0}$ \times 216.0 $^{+0.5}_{-0}$ mm	254.0 $^{+0.5}_{-0}$ \times 184.0 $^{+0.5}_{-0}$ mm	189.0 $^{+0.5}_{-0}$ \times 134.0 $^{+0.5}_{-0}$ mm

2. Specifications

Item		TS4150i	TS4120i	TS4100i	TS4070i
Unit color	Casing	Black			
	Surface sheet	Silver			
Material	Casing	PBT + GF30 resin			
	Surface sheet	PET: 0.188 mm			

- *1 Use the unit in an environment where the wet-bulb temperature is 39 °C or less, otherwise the unit may be damaged.
- *2 This indicates the distribution section to which the unit is intended to be connected to within the path between the distribution of the public power network and machinery in the facility. "Category II" applies to devices supplied with power from mains sockets or similar points. The withstand surge voltage is 500 V for devices rated up to 50 V.
- *3 This is an index that expresses the degree of conductive pollution in the environment where the unit is used.
"Pollution degree 2" indicates the condition where only non-conductive pollution occurs. However, due to condensation, temporary conductive pollution may occur.
- *4 Protective structure for the front when the TS4000 series unit is mounted on a mounting panel.
While the protective structure has passed compliance testing, it is not guaranteed under all environments.
- *5 To ensure stable protection, it is recommended to periodically check the tightening torque of the mounting screws.
- *6 To achieve a protective structure compliant with IP65, use the optional waterproof gasket.
- *7 Even when the mounting panel thickness is within the specified range, the panel itself may warp depending on the material and size of the mounting panel.
Use a panel that can withstand the forces of mounting.

2.1.2 Performance Specifications

Item		TS4150i	TS4120i	TS4100i	TS4070i
Display specifications	Display device	TFT color			
	Screen size	15.6-inch widescreen	12.1-inch widescreen	10.1-inch widescreen	7.0-inch widescreen
	Dots (resolution)	1366 × 768 dots	1280 × 800 dots	1024 × 600 dots	800 × 480 dots
	Dot pitch	0.252 × 0.252 mm	0.204 × 0.204 mm	0.2175 × 0.2088 mm	0.1926 × 0.179 mm
	Actual display dimensions	344.2 × 193.5 mm	261.1 × 163.2 mm	222.7 × 125.3 mm	154.1 × 85.9 mm
	Colors	16.77 million colors ^{*1}	16.20 million colors ^{*1}	16.77 million colors ^{*1}	
	Backlight	LED			
	Backlight brightness halftime ^{*2}	Approx. 50,000 hours		Approx. 30,000 hours	Approx. 45,000 hours
	Backlight auto OFF function	Always ON, custom setting			
	Brightness adjustment	System menu: 16 levels Macro: 128 levels			
Touch switch	Type	Analog resistive film type			
	Switch resolution	4096 × 4096			
	Mechanical life	One million activations or more			
	Surface treatment	Anti-glare treatment			
Clock and backup memory specifications	Backup retention period	Approx. 5 years (ambient temperature at 25 °C)			
	Calendar accuracy ^{*3}	When powered: Monthly deviation of ±228 sec. (ambient temperature at 25 °C) When unpowered: Monthly deviation of ±80 sec. (ambient temperature at 25 °C, with battery backup)			
	Backup memory	SRAM, 230 KB			
	Replacement battery	Coin-type lithium primary cell (TS-BT manufactured by Hakko Electronics)			
	Battery voltage drop detection	Provided (allocated to internal device memory address \$s167)			

*1 This is for picture parts and 3D parts only. All other content is displayed using 65,536 colors.

*2 Time until the surface brightness becomes 50 % of the initial value at an ambient temperature of 25 °C.

*3 When using the unit at an ambient temperature other than 25 °C, clock deviation may increase. Check and correct the clock periodically.

2.1.3 Interface Specifications

Item		Specifications
COM1	Number of ports	1
	Connector	D-sub 9-pin female
	Communication standard	RS-422 (4-wire connection), RS-485 (2-wire connection) ^{*1}
	Synchronization	Asynchronous type
	Data length	7 or 8 bits
	Parity	None, even, odd
	Stop bit	1 or 2 bits
	Baud rate	4800, 9600, 19200, 38400, 57600, 76800, 115 kbps (For PPI/MPI connection with a Siemens PLC: 187.5 kbps ^{*2})
Applications	Connection with a PLC, temperature controller, various controllers, multi-link2, V-Link, etc.	
COM2 ^{*3}	Number of ports	1
	Connector	D-sub 9-pin male
	Communication standard	RS-232C
	Baud rate	4800, 9600, 19200, 38400, 57600, 76800, 115 kbps
	Applications	Connection with a PLC, temperature controller, various controllers, barcode reader, printer, V-Link, etc.
COM3 ^{*3}	Number of ports	1
	Connector	D-sub 9-pin male
	Communication standard	RS-485 (2-wire connection)
	Baud rate	4800, 9600, 19200, 38400, 57600, 76800, 115 kbps
	Applications	Connection with a PLC, temperature controller, various controllers, multi-link2, V-Link, etc.
U-A	Number of ports	1
	Connector	USB 2.0 Standard-A (Type-A)
	Conforming standards	USB 2.0
	Baud rate	Low speed: 1.5 Mbps, Full speed: 12 Mbps, High speed: 480 Mbps
	Cable length	Max.: 5 m
	Applications	Connection with a printer, USB flash drive, barcode reader, keyboard, mouse, etc.
U-B	Number of ports	1
	Connector	USB 2.0 mini-B
	Conforming standards	USB 2.0
	Baud rate	Low speed: 1.5 Mbps, Full speed: 12 Mbps, High speed: 480 Mbps
	Cable length	Max.: 5 m
	Applications	Screen program transfer
LAN (Ethernet)	Number of ports	1
	Connector	RJ-45
	Conforming standards ^{*4}	IEEE802.3u / IEEE802.3
	Baud rate	10 Mbps, 100 Mbps
	Protocol	TCP/IP, UDP/IP
	Function	Auto-MDIX, Auto-Negotiation
	Recommended cable ^{*5}	100 Ω UTP (unshielded twist-pair) cable, category 5 Max. length = 100 m
	Applications	Screen program transfer, connection with PLC, printer, etc.

^{*1} DIP switches on the back of the unit are used to switch between RS-422 (4-wire connection) and RS-485 (2-wire connection). For details, refer to "3.2.6 DIP Switches (DIPSW)" page 3-11.

^{*2} For details, refer to the Connection Manual 3.

^{*3} Communication for the two ports, COM2 and COM3, are supported by the same connector. COM2 and COM3 can be used simultaneously.

^{*4} Jumbo frames are not supported.

^{*5} Both straight and crossover cables are usable, irrespective of the presence or absence of a hub.

2.1.4 Screen Configuration Environment

Item		Specifications
Configuration method		Dedicated configuration software
Configuration tool	Dedicated software name	Smart Editor
	OS *1	Windows 10 (64-bit) / 11 (64-bit)
	CPU	Windows 10: Intel Core 2 Duo, 2 GHz or above recommended Windows 11: Dual-core (minimum), 64-bit capable processor, or System-on-a-Chip (SoC)
	Memory	8 GB or more recommended
	Hard disk capacity	At installation: 5.0 GB or more
	Optical disc drive	DVD-ROM drive
	Display	Resolution: 1920 × 1080 dots (Full HD) or higher
Others		<ul style="list-style-type: none"> • Microsoft .NET Framework 4.0 or higher • Visual Studio 2015-2022 Visual C++ Redistributable Package (Installed automatically upon installation of Smart Editor if not already installed on your computer)

*1 Administrator privileges are required for installation.

2.1.5 Display Function Specifications

Item		Specifications
Interface language *1		Japanese, English/Western Europe, Chinese (Traditional), Chinese (Simplified), Korean, Central Europe, Cyrillic, Greek, Turkish, Baltic
Font types		TrueType fonts, Bitmap fonts, Windows fonts, Gothic fonts
Character properties	Display properties	Normal, blink, bold, shadow, transparent, italic
	Color	65,536 colors (without blinking), 32,768 colors (with blinking)
Graphics	Lines	Line, continuous line, box, parallelogram, polygon
	Circles	Circle, arc, sector, ellipse, elliptical arc
	Others	Pattern, "picture" image, data display (graphics library, data sheets)
Graphic properties	Line type	6 types (thin, thick, dotted, chain, dashed, two-dot chain) Line thickness can be selected from 1 to 8 points (excluding thick lines).
	Tile	16 types (including 8 user-definable patterns)
	Display properties	Normal, blinking
	Colors	65,536 colors (without blinking), 32,768 colors (with blinking)
	Color selection	Foreground, background, boundary (line)

*1 For details, refer to the Reference Manual 1.

2.1.6 Function Performance Specifications

Item		Specifications
Screens		Max. 4,000
Screen memory		128 MB of flash memory
Switches		Max. 4,096 switches per screen ^{*1} (including slider switches and scroll bars)
Switch actions		Set, reset, momentary, alternate, illuminated
Lamps		Reverse, blinking, exchange of graphics Max. 4,096 per screen ^{*1}
Graphs		Pie, bar, panel meter and closed area graph: Max. 4,096 per screen ^{*1} Statistics and trend graphs: Max. 256 per layer ^{*2}
Data setting	Numerical data display	Max. 4,096 per screen ^{*1}
	Character display	Max. 4,096 per screen ^{*1}
	Message display	Max. 4,096 per screen ^{*1} Maximum number of characters per line: 100 one-byte characters
Messages		Max. 32,768 lines
Macro blocks		Max. 1,024
Graphics library		Max. 2,560
Overlap library		Max. 4,000
Screen library		Max. 4,000
Data blocks		Max. 1,024
Patterns		Max. 1,024
Data sheets		Max. 1,024
Tags		Max. 65,536 lines
Page blocks		Max. 2,048
Direct blocks		Max. 1,024
Screen blocks		Max. 1,024
Comments		Max. 32,767
Logging server		Fixed cycle, trigger
Alarm server		Real time, alarm, event
Recipes		Max. 256
Scheduler		Max. 64
MES setting		Max. 256
Device memory map		Max. 32 × 8 (PLC1 to PLC8)
Time display		Provided
Hard copy		Provided
Buzzer		Provided, 3 sounds (short beep, long beep, continuous beep)
Auto OFF function		Always ON, custom setting
Self-diagnostic function		Touch switch test function ^{*3} Confirmation function that uses the status bar ^{*3} Network diagnostic functions (network test, duplicate IP address test) ^{*3}

*1 The maximum number of parts that can be placed on one screen is 4,096.

For more information on limitations regarding part placement, refer to the Introductory Manual.

*2 Layer: 11 layers per screen (base screen and 10 overlap displays)

*3 For details, refer to the Unit Operation / Local Mode / Error Screen Manual provided separately.

2.2 External Dimensions and Panel Cut-out Dimensions

2.2.1 TS4150i

- Front view

(Unit: mm)

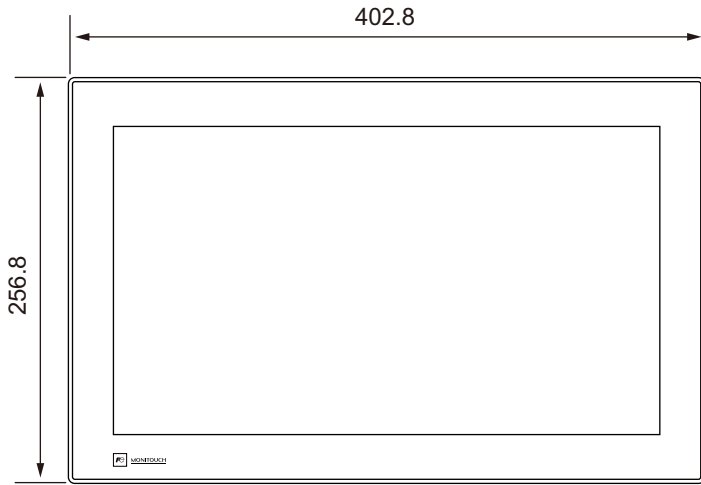

- Rear view

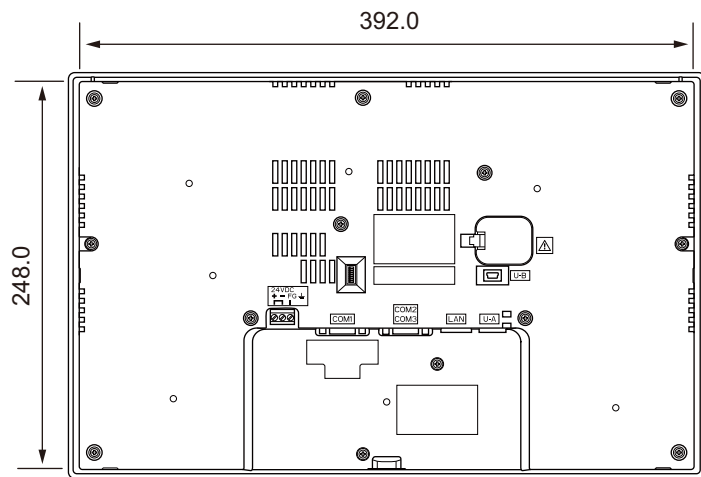

- Side view

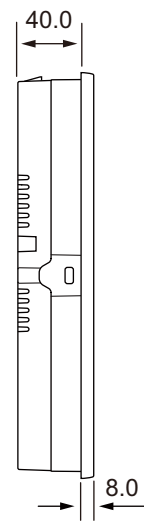

- Bottom view

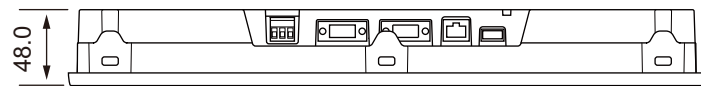

- Panel cut-out dimensions

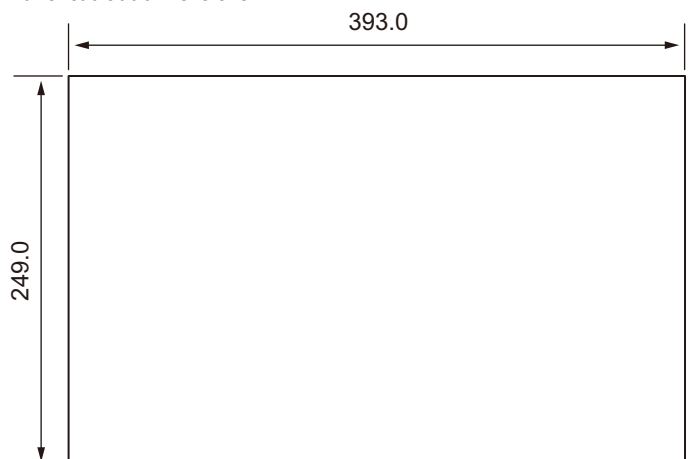

2.2.2 TS4120i

(Unit: mm)

- Front view

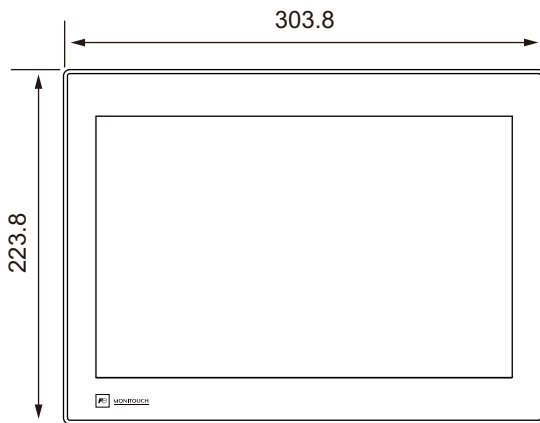

- Rear view

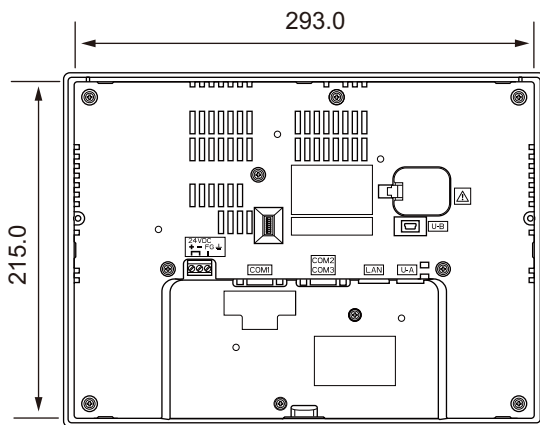

- Side view

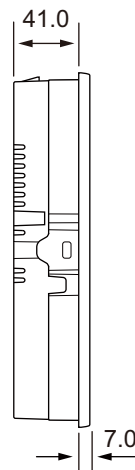

- Bottom view

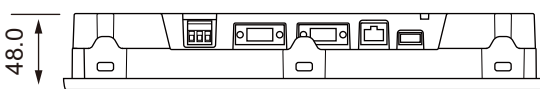

- Panel cut-out dimensions

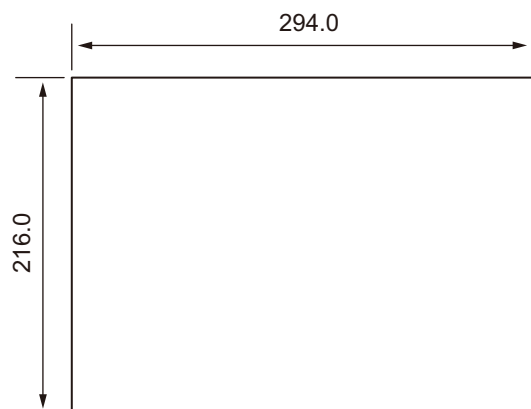

2.2.3 TS4100i

- Front view

(Unit: mm)

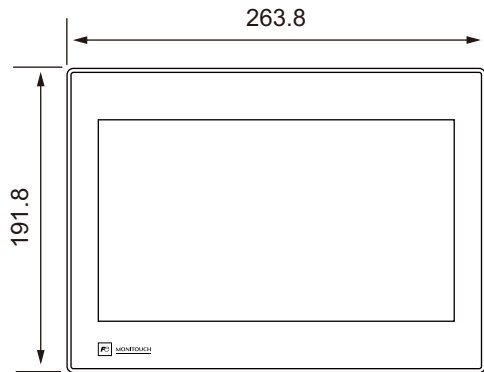

- Rear view

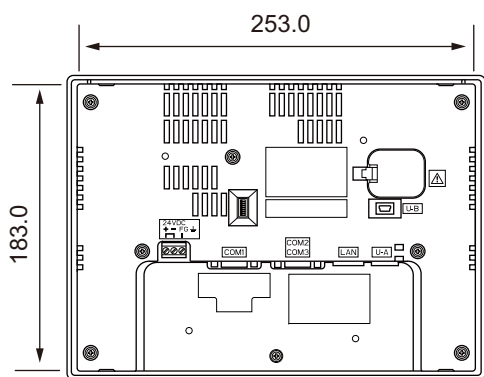

- Side view

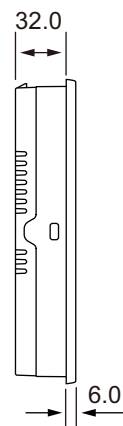

- Bottom view

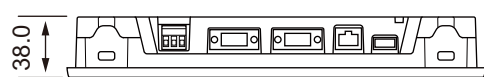

- Panel cut-out dimensions

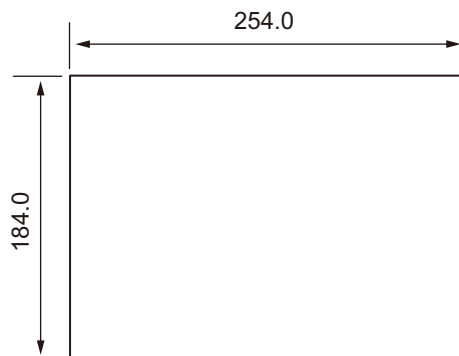

2.2.4 TS4070i

(Unit: mm)

- Front view

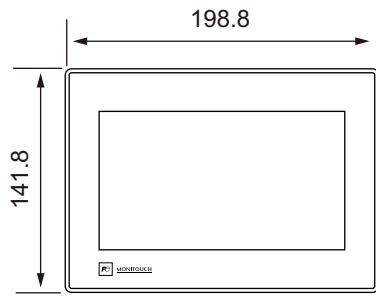

- Rear view

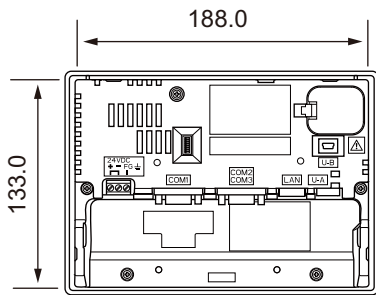

- Side view

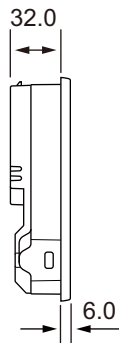

- Bottom view

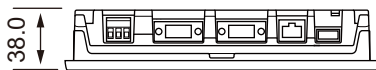

- Panel cut-out dimensions

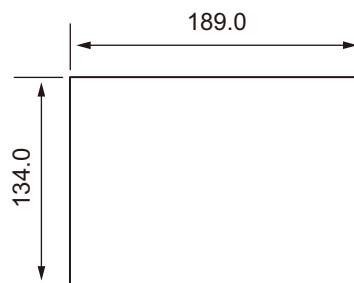

3 Names and Specifications of Components

3.1 Names and Functions of Components

3.2 Specifications of Components

3.1 Names and Functions of Components

TS4150i

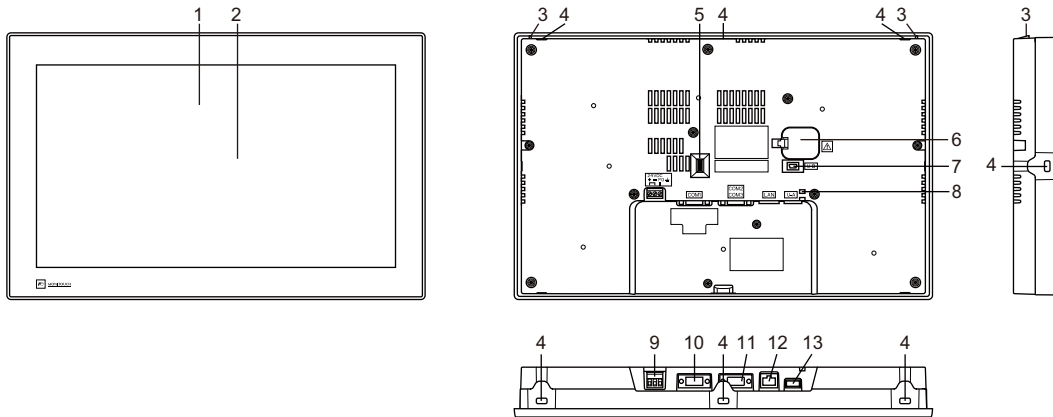

TS4120i

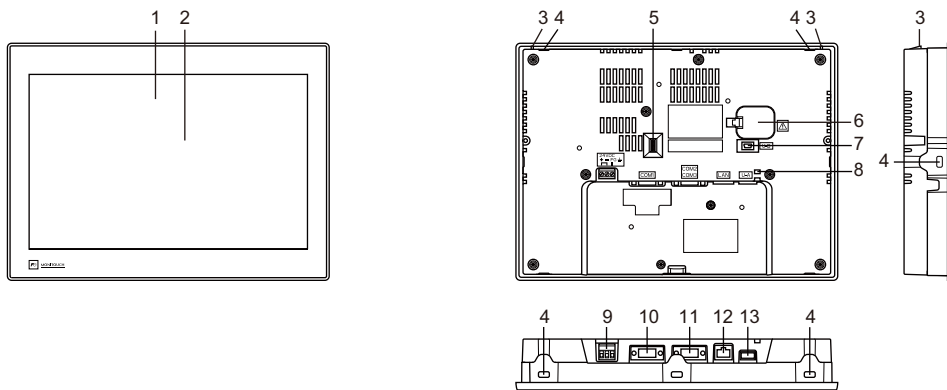

TS4100i

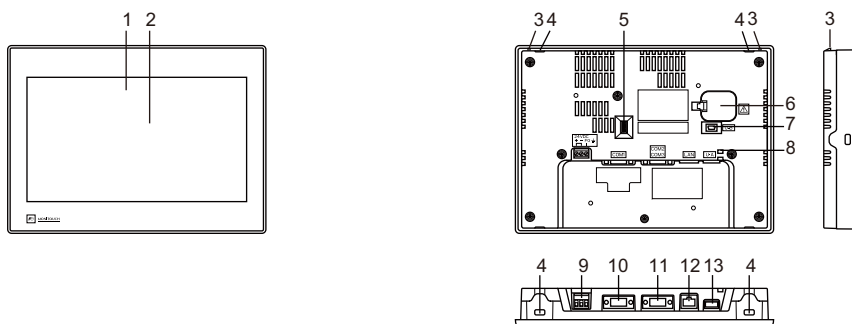

TS4070i

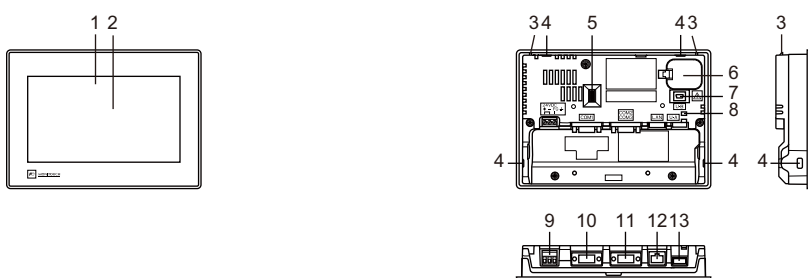

3. Names and Specifications of Components

No.	Name	Description	Refer to
1	Display	Display area	-
2	Touch switch	Analog resistive film type touch switch area	-
3	Fall prevention tab	Projections to prevent the unit from falling when installed on a mounting panel	page 4-1
4	Mounting hole	Holes for inserting mounting fixtures	page 4-1
5	DIP switch	Terminating resistance for serial communication, etc.	page 3-11
6	Battery holder	For mounting a battery for SRAM/clock backup	page 4-7
7	U-B	USB version 2.0 mini-B port	page 3-9
8	USB cable clamp hole	Hole for attaching a cable tie for clamping a USB cable	page 4-6
9	Power supply terminal block	Terminal block for power supply to the TS4000 unit	page 4-4
10	COM1	Serial communication port (RS-422/RS-485) Connection with PLCs or other peripheral devices	page 3-3
11	COM2/COM3	Serial communication port (COM2: RS-232C, COM3: RS-485) Connection with PLCs or other peripheral devices	page 3-4
12	LAN	Wired LAN port	page 3-10
13	U-A	USB version 2.0 Type-A port	page 3-5

3.2 Specifications of Components

3.2.1 COM1

This connector is used for RS-422/485 connection with controllers.

- TS4150

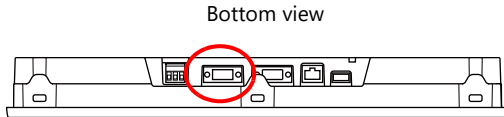

- TS4100

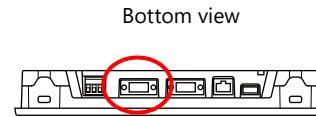

Specifications

Item	Specifications
Number of ports	1
Connector	D-sub 9-pin female
Communication standard	RS-422 (4-wire connection), RS-485 (2-wire connection)
Synchronization	Asynchronous type
Data length	7 or 8 bits
Parity	None, even, odd
Stop bit	1 or 2 bits
Baud rate	4800, 9600, 19200, 38400, 57600, 76800, 115 kbps (For PPI/MPI connection with a Siemens PLC: 187.5 kbps ^{*1})

*1 For details, refer to the Connection Manual 3.

Pin Numbers and Signal Names

COM1 (D-sub 9-pin, female) ^{*1}	Pin No.	RS-422 (4-wire connection) ^{*2, *3}		RS-485 (2-wire connection) ^{*2, *3}	
		Signal Name	Description	Signal Name	Description
	1	+ RD	Receive data (+)	+ SD/RD	Send/receive data (+)
	2	- RD	Receive data (-)	- SD/RD	Send/receive data (-)
	3	- SD	Send data (-)	-	-
	4	+ SD	Send data (+)	-	-
	5	SG	Signal ground	SG	Signal ground
	6	NC	Not used	NC	Not used
	7				
	8				
	9				

*1 FG indicates "Frame Ground". Connect the shielded cable of the communication cable to the connector housing.

*2 The terminating resistance needs to be set. Set the terminating resistance using DIP switches 6 and 7 on the back of the unit.
For details, refer to "3.2.6 DIP Switches (DIPSW)" page 3-11.

*3 Use DIP switches 2 and 3 on the back of the unit to switch between RS-422 (4-wire connection) and RS-485 (2-wire connection).
For details, refer to "3.2.6 DIP Switches (DIPSW)" page 3-11.

Recommended Connector

Recommended connector	Specifications
DDK's 17JE-23090-02(D8C)-CG	D-sub 9-pin / male / inch screw thread (#4-40UNC) type / with hood / lead and cadmium free

Applications

Application	Screen configuration software setting	Refer to
PLC/temperature controller connection	Required	Connection Manual
Multi-link/Multi-link2 communication	Required	
V-Link connection	Required	

3.2.2 COM2/COM3

COM2: This connector is used for connecting a controller or barcode reader via RS-232C.
 COM3: This connector is used for connecting a controller via RS-485 (2-wire connection).

- TS4150

Bottom view

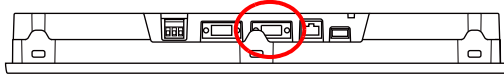

- TS4100

Bottom view

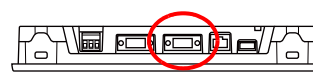

Specifications

Item	COM2	COM3
Number of ports	1	1
Connector	D-sub 9-pin male	
Communication standard	RS-232C	RS-485 (2-wire connection)
Synchronization	Asynchronous type	
Data length	7 or 8 bits	
Parity	None, even, odd	
Stop bit	1 or 2 bits	
Baud rate	4800, 9600, 19200, 38400, 57600, 76800, 115 kbps	

*1 For details, refer to the Connection Manual 3.

Pin Numbers and Signal Names

COM2/COM3 *1 *2 (D-sub 9-pin, male)	Pin No.	COM2 (RS-232C)		COM3 (RS-485) *3	
	1	-	-	- SD/RD	Send/receive data (-)
	2	RD	Receive data	-	-
	3	SD	Send data	-	-
	4	NC	-	-	-
	5	SG	Signal ground	-	-
	6	-	-	+ SD/RD	Send/receive data (+)
	7	RTS	Request to send	-	-
	8	CTS	Send permission	-	-
	9	-	-	SG	Signal ground

*1 The same connector is used for COM2 and COM3. Simultaneous communication is possible.

*2 FG indicates "Frame Ground". Connect the shielded cable of the communication cable to the connector housing.

< Example handling of shielded cable for when using COM2 and COM3 simultaneously >

- Collect the shielded cables into one using a relay terminal block and collectively connect to the COM2/COM3 connector housing.
- The communication cable for connecting the COM2/COM3 connector with the relay terminal block is to be no longer than 2 meters.

For details, refer to the TS4000 Series Connection Manual.

*3 The terminating resistance needs to be set. Set the terminating resistance using DIP switch 8 on the back of the unit.

For details, refer to "3.2.6 DIP Switches (DIPSW)" page 3-11.

Recommended Connector

Recommended connector	Specifications
DDK's 17JE-13090-02(D8C)A-CG	D-sub 9-pin / female / inch screw thread (#4-40UNC) type / with hood / lead and cadmium free

Applications

Application	Screen configuration software setting	Refer to
PLC/temperature controller connection	Required	Connection Manual
Barcode reader connection (COM2)	Required	
Printer connection (COM2)	Required	
Multi-link/Multi-link2 communication (COM3)	Required	Reference Manual 1
V-Link	Required	Connection Manual

3.2.3 U-A

This is a USB-A connector used to connect a printer, USB flash drive, barcode reader, keyboard, mouse, or USB hub. USB version 2.0 is supported.

- TS4150

Bottom view

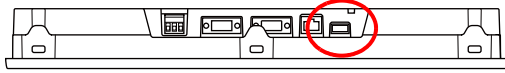

- TS4100

Bottom view

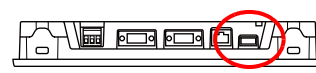

Enlarged view

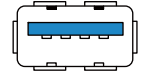

Specifications

Item	Specifications
Number of ports	1
Connector	USB 2.0 Standard-A (Type-A)
Conforming standards	USB 2.0
Baud rate	Low speed: 1.5 Mbps, Full speed: 12 Mbps, High speed: 480 Mbps
External power supply current	5 V / 500 mA
Cable length	Max. 5 m

Applications

Application	Screen configuration software setting	Refer to
Printer connection	Required	Reference Manual 1
USB flash drive connection	Required	Refer to page 3-5 .
Barcode reader connection	Required	Connection Manual 3
Keyboard/numeric keypad connection	Required	Refer to page 3-6 .
Mouse connection	Not required	Refer to page 3-7 .
USB hub connection	Not required	Refer to page 3-8 .

USB Flash Drive

A USB flash drive can be connected to the TS4000 series unit to perform operations including screen program transfer and saving of log data.

Connection Example

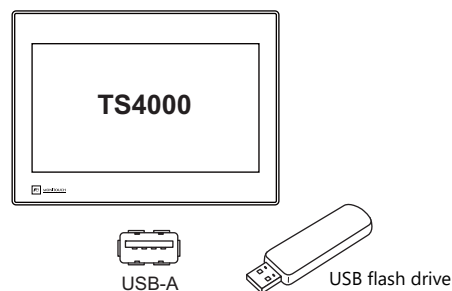

USB flash drive

Storage	Capacity	File system
USB flash drive	Max. 2 TB	FAT, FAT32, exFAT *

* When a file is saved with TS4000, the created date and time (new creation only) and the updated date and time of the file are set to Coordinated Universal Time (UTC+0:00). Therefore, when you check the created and updated dates and times of the file on your PC, the date and time discrepancy occurs depending on the time zone of your PC.

However, this does not affect the time stamp added to the filename in some functions or the time data output in the file.

Screen Configuration Software Settings

Required settings vary according to the application. For details, refer to Reference Manual 2.

Notes



- USB flash drives that have a security function cannot be used.
- When removing a USB flash drive, select [Storage Removal] in the system menu, or press the [Storage Removal] switch.
- Do not turn off power to the unit when the USB flash drive is being accessed.
- Make a backup copy of the USB flash drive at regular intervals.
- If a disk error occurs and data read/write operation is disabled, execute ScanDisk on Windows and try to restore the disk. If the disk cannot be restored, format the storage device. Note that formatting will completely erase all stored data. (For information on executing ScanDisk on Windows, refer to the relevant Windows manual.)
- USB flash drives have a limited number of write cycles. Consequently, frequent writing at short intervals may shorten the service life of USB flash drives. When using a USB flash drive to save logging/alarm data, take the logging time/monitoring intervals into consideration. Also, avoid repeated writing using the CYCLE macro command.

Keyboard and Numeric Keypad

Numeric values and characters can be entered by connecting a keyboard or numeric keypad to the TS4000 series unit.

Connection Example

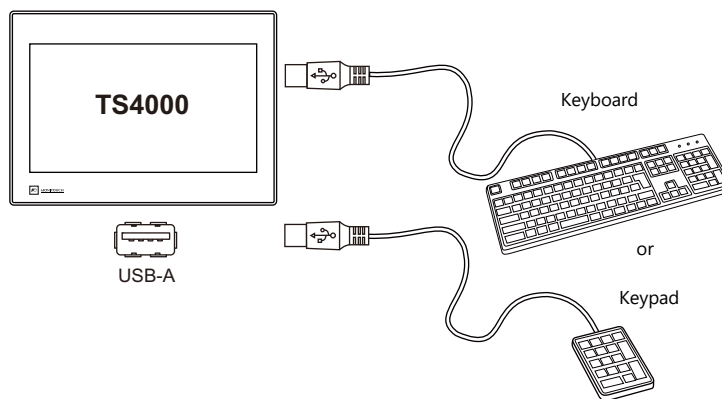

Compatible Keyboards

Type	Type
Japanese keyboard	106 keyboard, 109 keyboard, etc.
US standard keyboard	101 keyboard, 104 keyboard, etc.
Keypad	

Screen Configuration Software Settings

An [Entry Mode] must be registered on the screen where the keyboard is to be used.

In addition, placement of numerical data or character display parts with [Entry Target] selected for [Function] is required.

For details, refer to the Reference Manual 1.

TS4000 Series Unit Settings

Select the type of keyboard to connect at [Language Setting] → [Keyboard] in the Local mode.

For details, refer to the Reference Manual 1.

Mouse

A mouse can be used to operate screens displayed on the TS4000 series unit by connecting a mouse to the unit.

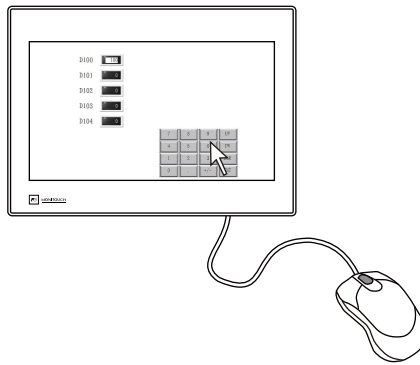

The mouse pointer displayed on the unit is shown below.



Connection Example

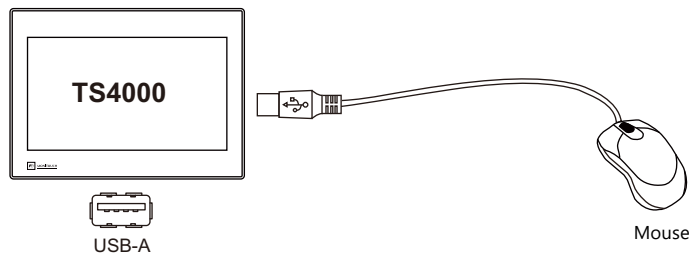

Mouse Operation

The mouse operations available on the unit are shown below.

Mouse operation	Action
Movement	Moving the mouse pointer
Left-click	Pressing a switch

Barcode Reader

Character string data can be read by connecting a barcode reader to the TS4000 series unit.

Connection Example

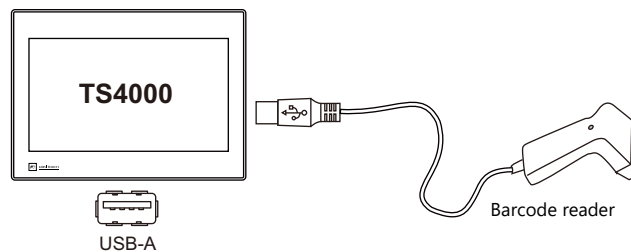

Connectable Barcode Readers

Use a USB barcode reader which is compliant with USB-HID.

Screen configuration software setting

For details, refer to the Reference Manual 1.

TS4000 Series Unit Settings

Select the type of barcode reader to connect at [Language Setting] → [Keyboard] in the Local mode.

For details, refer to the Reference Manual 1.

USB Hub

Devices like printers can be used at the same time by connecting a USB hub to the TS4000 series unit.

Connection Example

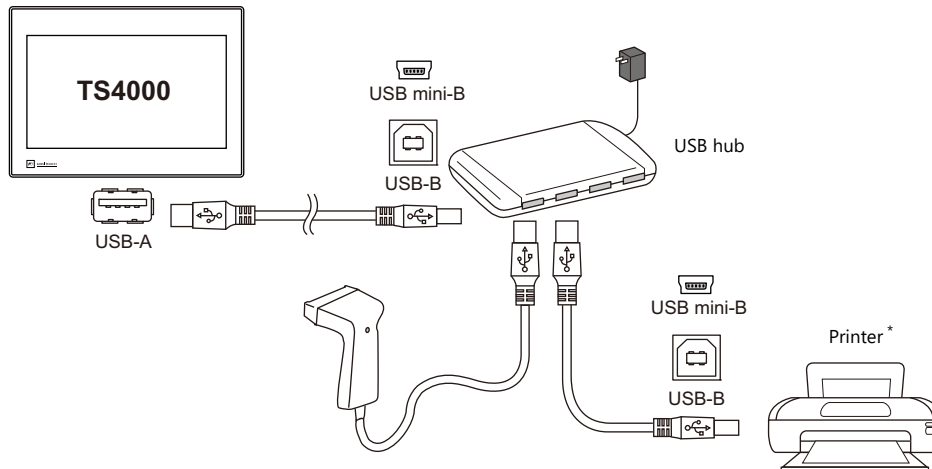

* A parallel printer can also be connected. (In this case, a parallel printer that is compatible with the TS4000 series and a commercially available parallel-to-USB cable must be used (recommended cable: UC-PGT manufactured by ELECOM). For more information on compatible printer models, visit our website (www.monitouch.com/).

Combinations of Connected Devices

Combination of devices usable at the same time: ○, Combination of devices not usable at the same time: × (Same equipment: -)

	Printer	USB flash drive	USB barcode reader	Keyboard Keypad	USB mouse
Printer	-	○	○	○	○
USB flash drive	○	-	○	○	○
USB barcode reader	○	○	-	× *	○
Keyboard Keypad	○	○	× *	○	○
USB mouse	○	○	○	○	○

* If these devices are connected at the same time, only the USB barcode reader will be recognized.

Notes



- A maximum of two USB hubs (cascaded) can be connected to the TS4000 series. Note that, however, the system's performance may slow down when two hubs are used.
- When a USB hub is connected to a TS4000 series unit and is using the power adaptor provided with the USB hub, do not turn off the power adaptor or disconnect the connector between the power adaptor and the USB hub. Doing so may prevent sufficient power supply to the TS4000 series unit resulting in faulty operation such as repeated restarting.
- When connecting two USB hubs to the TS4000 series unit, supply power to each USB hub using the adaptor provided with each hub. Even when connecting only one USB hub, use the provided power supply adaptor (if provided).

3.2.4 U-B

This is a USB mini-B connector used for screen program transfer.
It complies with USB version 2.0.

- TS4150

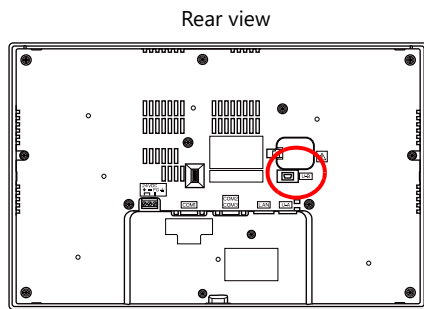

- TS4100

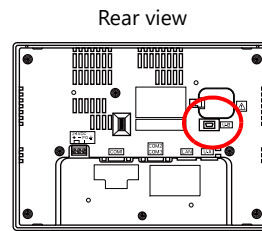

Enlarged view



Specifications

Item	Specifications
Number of ports	1
Connector	USB 2.0 mini-B
Conforming standards	USB 2.0
Baud rate	Low speed: 1.5 Mbps, Full speed: 12 Mbps, High speed: 480 Mbps
Cable length	Max.: 5 m

Applications

Application	Screen configuration software setting	Refer to
Ladder transfer function *1	Required	Reference Manual 2
Screen program transfer	Not required	Introductory Manual

*1 The ladder transfer function cannot be used simultaneously with 1:n communication (multi-drop) or multi-link communication.

3.2.5 LAN

This connector is used for Ethernet communication with controllers.

- TS4150

Bottom view

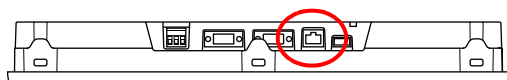

- TS4100

Bottom view



Specifications

Item	Specifications
Number of ports	1
Connector	RJ-45
Conforming standards *1	IEEE802.3u / IEEE802.3
Baud rate	100 Mbps, 10 Mbps
Protocol	TCP/IP, UDP/IP
Function	Auto-MDIX*2, Auto-Negotiation
Recommended cable	100 Ω UTP (unshielded twist-pair) cable, category 5 or above, max. 100 m

*1 Jumbo frames not supported

*2 Both straight and crossover cables are usable, irrespective of the presence or absence of a hub.

Applications

Application	Screen configuration software setting	Refer to
PLC/temperature controller connection	Required	Connection Manual
Multi-link2 (Ethernet) / 1:n Multi-link2 (Ethernet) communication	Required	
Ladder transfer function *1	Required	Reference Manual 2
Screen program transfer	Not required	Introductory Manual
Ethernet communication function	Required	Reference Manual 2
Network printer connection	Required	Reference Manual 1
VPN remote access service Cloud data service	Not required	Web Machine Interface Manual

*1 The ladder transfer function cannot be used simultaneously with 1:n communication (multi-drop) or multi-link communication.

Pin Numbers and Signal Names

LAN	Pin No.	100BASE-TX / 10BASE-T	
	1	TX+	Transmit signal +
	2	TX-	Transmit signal -
	3	RX+	Receive signal +
	4	NC	Not used
	5	NC	Not used
	6	RX-	Receive signal -
	7	NC	Not used
	8	NC	Not used

Wiring



- Do not connect any peripheral device that will carry excess voltage to the LAN connector.
- Keep the LAN cable away from the power supply cable as much as possible.

- Use a commercially available cable. Using a self-made cable may cause an error in network connection.

3.2.6 DIP Switches (DIPSW)

The TS4000 series unit is equipped with DIP switches 1 to 8. Turn off power to the unit before changing any DIP switches. Upon delivery, all DIP switches are set to OFF.

• TS4150

Rear view

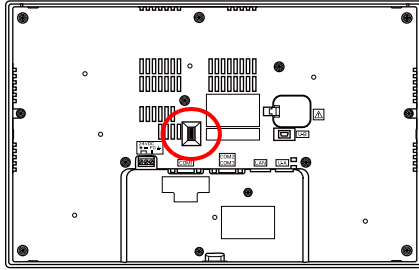

• TS4100

Rear view

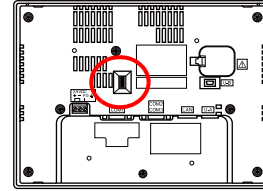

DIPSW	No.	Item	Description	
<p>OFF → ON</p>	1	Storage automatic upload	<p>Set to ON to automatically upload a screen program from a storage device (USB flash drive).</p> <p>* When not using automatic upload, always set DIP switch 1 to OFF.</p> <p><Uploading procedure></p> <ol style="list-style-type: none"> Preparation of storage Use the screen configuration software to load a screen program onto a storage device. (For the loading procedure, refer to Reference Manual 2.) Connection of storage Turn OFF power to the TS4000 unit and connect the storage device to the USB-A port. DIP switch settings Slide DIP switch 1 rightward to the ON position. Automatic upload start Turn ON power to the TS4000 unit. The screen program is automatically loaded into the flash memory of the TS4000 unit. Removal of storage After uploading of the screen program is completed, turn OFF power to the TS4000 unit and slide DIP switch 1 leftward to the OFF position. Remove the storage device from the USB-A port. 	
	2	COM1	4-wire/2-wire connection switching	<p>When connecting via RS-422 (4-wire connection): Set DIP switches 2 and 3 to OFF. When connecting via RS-485 (2-wire connection): Set DIP switches 2 and 3 to ON.</p>
	3			
	4	COM1	Siemens MPI/PPI terminating resistance	<p>When communicating using MPI/PPI with a Siemens PLC: Set DIP switches 4 and 5 to ON.</p>
	5			
	6	COM1	Terminating resistance	<p>When connecting via RS-422 (4-wire connection): Set DIP switches 6 and 7 to ON. When connecting via RS-485 (2-wire connection): Set DIP switch 7 to ON.</p>
	7			
	8	COM3	Terminating resistance	<p>When connecting via RS-485 (2-wire connection): ON</p>

4 Installation

- 4.1 Installation
- 4.2 Power Supply
- 4.3 Securing USB Cables
- 4.4 Battery

4.1 Installation

4.1.1 Installation Procedure

1. If using the optional waterproof gasket "TS4xx0-WP", place the TS4000 series unit on a level surface with the display screen facing down and fit the waterproof gasket in the groove. If not using the waterproof gasket, proceed to step 2.

CAUTION The unit will not be waterproof if the waterproof gasket is not correctly inserted into the groove.

2. Mount the TS4000 series unit into the mounting panel (maximum thickness of 5.0 mm) while paying attention to the fall prevention tabs.

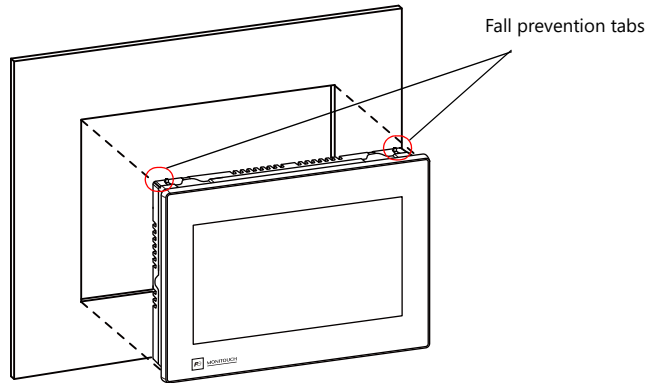

3. Insert the fixtures provided with the TS4000 series unit into the mounting holes at the locations shown below, and secure the TS4000 series unit with the tightening screws.

Series	Fixtures	Tightening torque
TS4150i	8 pcs	5.31 lbf-in (0.6 N-m)
TS4120i	6 pcs	
TS4100i	4 pcs	
TS4070i		

• TS4150i

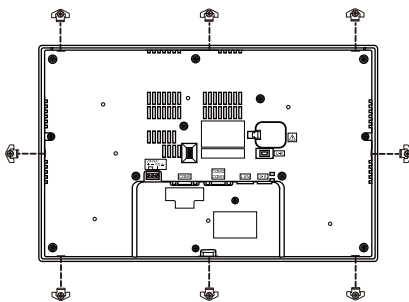

• TS4120i

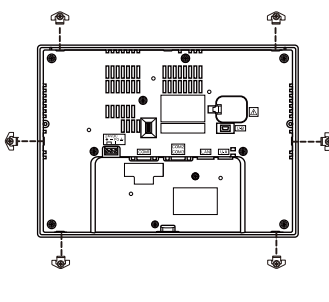

• TS4100i

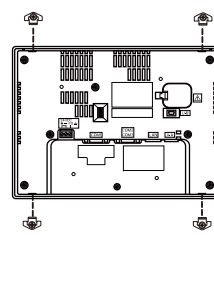

• TS4070i

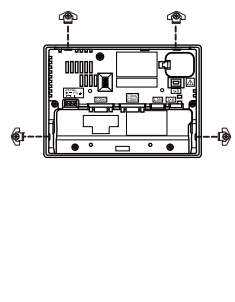

- Fixture dimensions (unit: mm)



- Section that protrudes when the unit is secured (unit: mm)

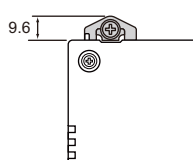

- * If the screws are tightened to a torque higher than stated above or the torque at each location is not equal, the surface sheet may warp due to deformation in the mounting panel and unit.
- * When mounting the TS4000 series unit rotated 90° to the right or left, insert and secure the fixtures in the same mounting holes shown in the figure below.
- * Ground the mounting panel to prevent any buildup of static electricity.
- * Periodical checking of the tightening torque of fixtures is recommended to ensure stable protection.

DANGER Failure to observe the above installation instructions and torque value may cause deformation, breakage, or malfunction of the touch switch, which may result in damage to the machine or an accident. If tightened insufficiently, the unit may fall, short-circuiting may occur, or the unit may malfunction.

4.1.2 Installation Conditions

Mounting Orientation

The TS4000 series can be mounted in the following orientations.

Example: TS4100i

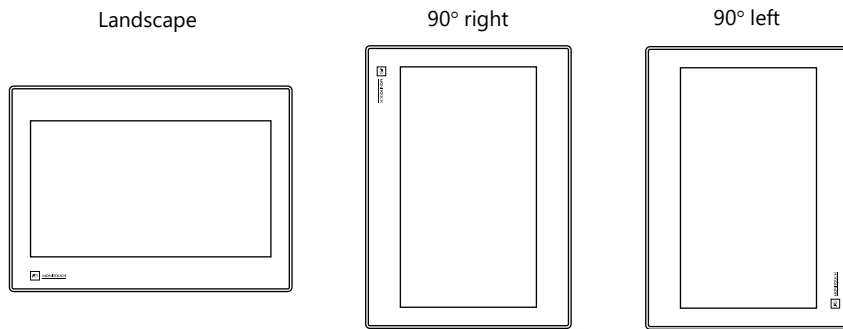

Mounting Angle

The mounting angle differs depending on the mounting orientation. Mount the unit within the angle ranges shown in the figure below.

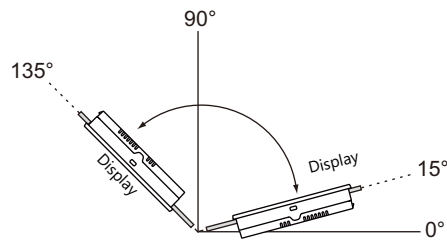

Panel Cut-out Dimensions

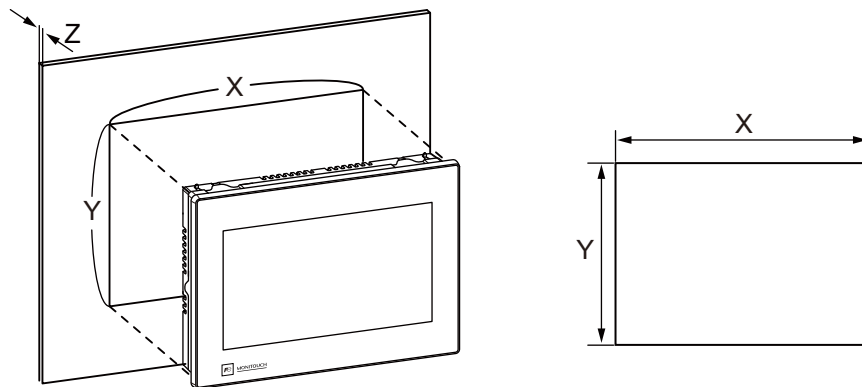

Unit: mm

Model	X	Y	Z (Panel thickness)
TS4150i	393.0 ^{+0.5} ₋₀	249.0 ^{+0.5} ₋₀	1.5 to 5.0
TS4120i	294.0 ^{+0.5} ₋₀	216.0 ^{+0.5} ₋₀	
TS4100i	254.0 ^{+0.5} ₋₀	184.0 ^{+0.5} ₋₀	
TS4070i	189.0 ^{+0.5} ₋₀	134.0 ^{+0.5} ₋₀	

Mounting Spatial Restrictions

Mount the TS4000 series unit with approximately 100 mm of space around the periphery of the unit.

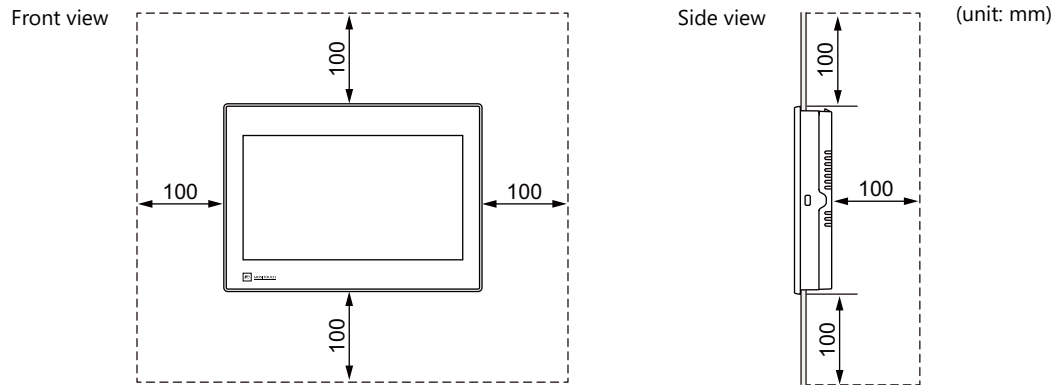

Ambient Temperature

Model	Operational Ambient Temperature
TS4150i	0 °C to +50 °C (wet-bulb temperature of 39 °C or less)
TS4120i	
TS4100i	
TS4070i	

4.2 Power Supply

4.2.1 Power Supply Terminal Block Specifications

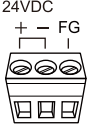
Item	Specifications	
	Model	PHOENIX CONTACT: MKDSN 2.5/3-5.08 SZS-SCREW
	Terminal shape	Pin type
	Recommended driver	PHOENIX CONTACT: SZS 0.6 x 3.5
	Tightening torque	5.0 to 6.0 lbf-in (0.56 to 0.68 N·m)

4.2.2 Power Supply Cable Specifications



CAUTION

- Do not solder the ends of wires. Doing so may lead to poor contact.
- When using stranded wire for cabling, make sure that the core is sufficiently twisted. Otherwise, stray wires may cause a short-circuit with a neighboring stray wire or electrode.
- In order to minimize drops in voltage, we recommend to use the thickest power supply cables possible and to twist the cables.

Item	Specifications	
Cable *1	24 V, 0 V	AWG18 to AWG14, discrete wire/solid wire (diameter: 1.0 to 1.6 mm), ferrule terminal allowed
	FG	AWG20 to AWG14, discrete wire/solid wire (diameter: 0.8 to 1.6 mm), ferrule terminal allowed
Stripping length		
Recommended ferrule terminal *2	PHOENIX CONTACT: AI 0,75-6 GY AI 1-6 RD AI 1,5-6 BK	
Recommended crimping tool	PHOENIX CONTACT: CRIMPFOX 6	

*1 For use in compliance with UL standards, a copper wire cable should be used and be stripped when connecting to the terminal block.

For details, refer to the instruction manual of the TS4000 series.

*2 Select a ferrule terminal appropriate to the cross-section area (diameter) of the electric wire.

4.2.3 Power Supply Cable Connection



DANGER

There is a risk of electrical shock. Shut the power off before connecting the power supply cable.

Connect the power supply cable to the terminal on the backside of the unit.

Example: TS4100i

Tightening torque
5.0 to 6.0 lbf-in
(0.56 to 0.68 N·m)

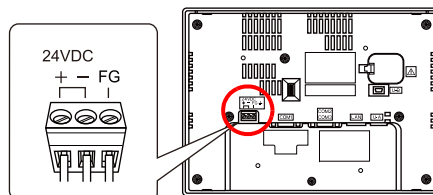

Notes on the Power Supply

- The power supply must be used within the allowable range of voltage fluctuation.
- Use a power supply with low noise between cables and between the ground and cables.
- Do not insert two wires into a single terminal on the terminal block.
- Keep power supply cables away from high-voltage, large-current carrying cables.
- For use in compliance with UL standards, use a Class 2 power supply with a safety extra-low voltage (SELV) circuit, or a power supply with a SELV circuit and limited energy (LIM) for 24 VDC power models.

4.2.4 Grounding

CAUTION Always ground the TS4000 series unit. (The level of grounding resistance should be $100\ \Omega$ or less.)

- Independent grounding must be used for the unit.
- Use AWG20 to AWG14 wire for the grounding cable.
- Set the grounding point near the unit to reduce the length of grounding cables.

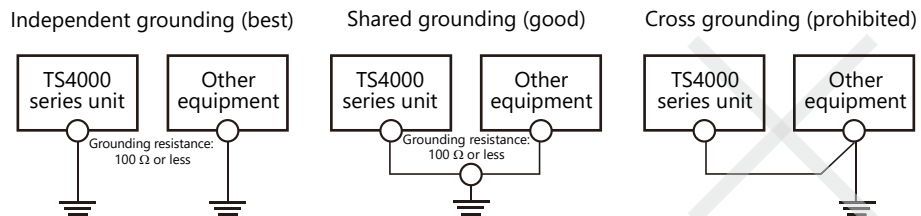

4.3 Securing USB Cables

USB cables may disconnect from the TS4000 series unit depending on the mounting conditions. Use the cable ties provided with the unit to prevent disconnection.

4.3.1 Securing Cables

1. Pass a cable tie through the hole as shown in the figure below. Pass the cable tie from the lower side upward.

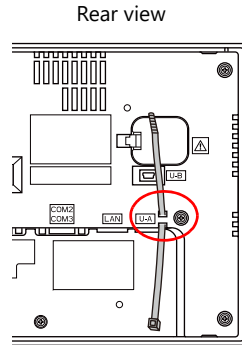

2. Connect a USB cable and secure it using the cable tie.

Example:

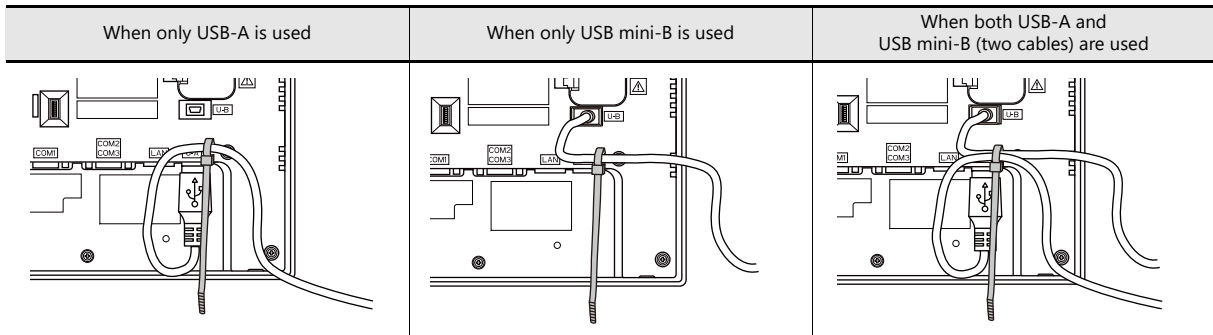

4.4 Battery

CAUTION A battery is already installed upon delivery.

4.4.1 Role of the Battery

The battery provides backup power to the user memory area in SRAM (non-volatile device memory \$L and \$LD, logging/alarm data) as well as the built-in clock.

4.4.2 Battery Replacement

CAUTION Use the screen configuration software or a storage device to make a backup copy of the data in SRAM before replacing the battery. If the power is turned off while the battery voltage is low, data in the SRAM area will be lost.

Replacement Battery

Replacement batteries are available.

Name	Model	Configuration
Replacement battery	TS-BT	<ul style="list-style-type: none"> Coin-type lithium primary cell 1 pce Caution sticker 1 pce

Battery Replacement Period

The service life of the battery is about 5 years from the date of manufacture.

When the battery voltage drops, the message "Battery changeover required" appears at the lower right in the Local mode on the TS4000 series unit.

* For information on the Local mode, refer to the Unit Operation / Local Mode / Error Screen Manual.

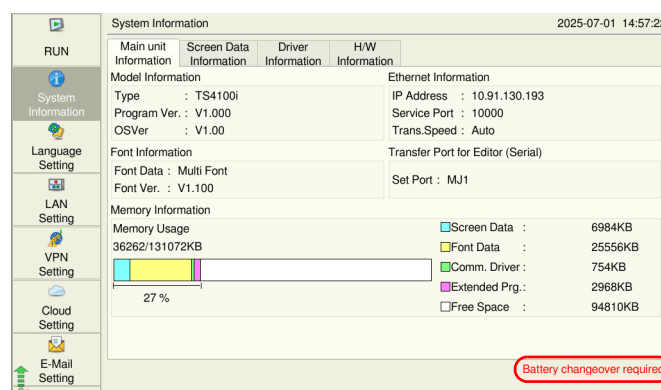

Battery Voltage Drop Detection

The battery status is output to the internal device memory address \$s167 of the TS4000 series unit.

When the battery voltage drops, the 4th bit of \$s167 turns ON.

If the battery voltage drops (4th bit turns ON) before the expiration date (about five years), replace the battery immediately.

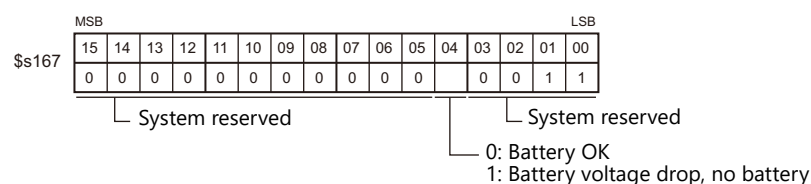

Safety Instructions on Handling Batteries

Lithium batteries contain combustible material such as lithium and organic solvents. Mishandling may cause heat, explosion, or ignition resulting in fire or injury. To prevent accidents, pay attention to the following cautions when handling lithium batteries.



- The battery has polarity. Make sure to insert the battery in the correct orientation. Inserting the battery in the wrong orientation may cause the battery to burst or ignite.
- The electrodes are exposed on the TS-BT battery. Do not carry or store the replacement battery together with metal objects. Short-circuiting of the electrodes may reduce battery capacity or cause the battery to burst or ignite.
- Do not disassemble, incinerate, or heat the battery.
- Never recharge the battery.

-
- Be sure to turn off the TS4000 series unit power and then replace the battery.
 - Only experts are authorized to perform battery replacement.
 - Be sure to discharge static electricity from your body before performing battery replacement.
 - Use the designated battery for replacement.
 - Rough handling of the battery may cause fire or chemical burns.
 - Observe local and governmental regulations when disposing of waste batteries.
 - Keep batteries out of reach of children. (If swallowed, immediately consult a doctor.)
 - If a battery leaks or smells, note that the leaking battery electrolyte is flammable. Keep away from heat or flame.
 - Transportation of batteries containing lithium metal must observe the relevant transport regulations.

SRAM Area Backup Procedure Before Battery Replacement

Use the screen configuration software or a storage device to make a backup copy of the data in SRAM.

Method Using the Screen Configuration Software

1. Connecting a cable
Connect the TS4000 series unit to a computer using a transfer cable (USB cable or Ethernet cable).
2. Starting the screen configuration software
Start the screen configuration software on the computer.
3. Displaying the [Transfer] dialog
Click [Transfer] → [Upload]. The [Transfer] dialog is displayed.
4. Selecting data to be transferred
Select [SRAM Data] for [Transfer Data].
5. Starting SRAM data transfer
Click the [PC <-] button. Data transfer from the SRAM is started.
6. Saving the SRAM data
When the SRAM data has been transferred, the [Save As] dialog is displayed on the computer. Save the data as a backup copy. The file extension is "*.RAM".
 - * To transfer the "*.RAM" data, which was saved as a backup copy, back to the TS4000 series unit, click [Transfer] → [Download] in step 3, and click the [PC ->] button in step 5.

Method Using a Storage Device

For details on the procedure for making backups using a storage device such as a USB flash drive, refer to the separate Unit Operation / Local Mode / Error Screen Manual.

Battery Replacement Procedure



DANGER

There is a risk of electrical shock. Be sure to turn off the TS4000 series unit power before starting the work.

1. Turn off the TS4000 series unit power.
2. Slide the battery holder cover in the direction of the arrow to open it.

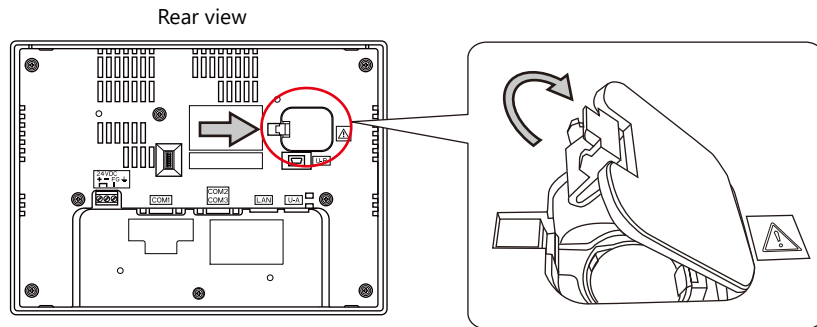

3. Press the tab to the right of the battery in the direction of the arrow. The right side of the battery will come up. Take the battery out with your fingers.

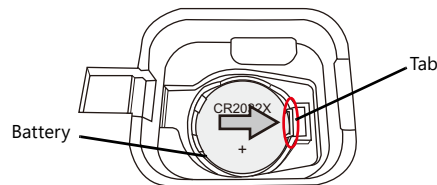

4. Slide a new battery leftward into the battery holder with the "+" side facing upward and then push down the right side of the battery until it clicks.

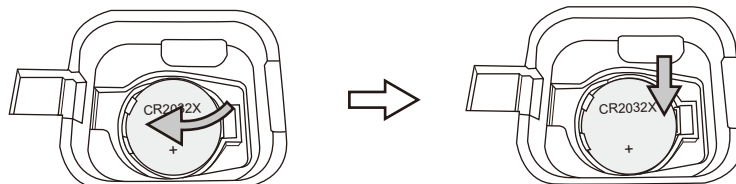

5. Close the battery holder cover by inserting the tab on the right side of the cover into the TS4000 unit and pressing the top of the cover on the left side until it clicks.

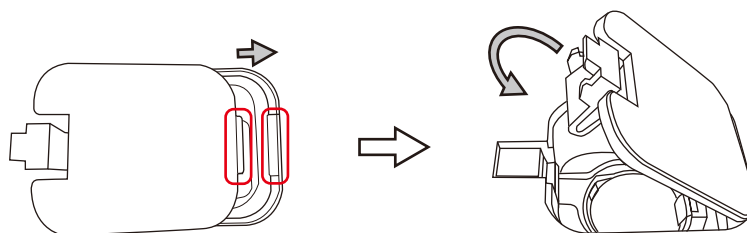

6. Remove the caution sticker on the rear face of the TS4000 series unit (circled below). Write a date five years from the present date for battery replacement on the new caution sticker and attach the sticker.

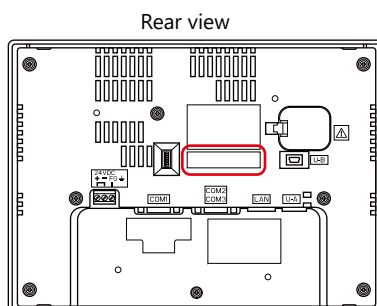

4. Installation

- Turn power ON to the TS4000 series unit and check that the message "Battery changeover required" is cleared from the lower right of the screen in Local mode.

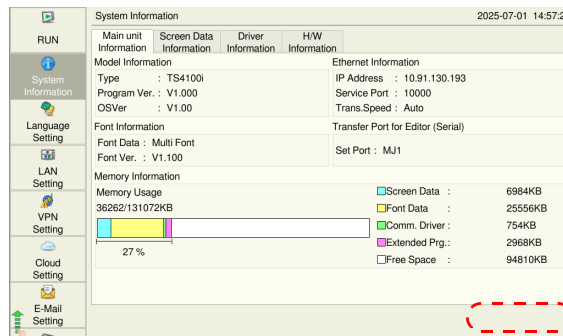

- If a "*.RAM" backup file was saved, transfer it back to the TS4000 series unit.

4.4.3 EU Battery Regulation 2023/1542

The TS4000 series is compliant with the EU Battery Regulation 2023/1542 which is effective in EU countries.

4.4.4 "Perchlorate Best Management Practices" Regulations of California State Law, USA

The TS4000 series is a product subject to the "Perchlorate Best Management Practices" regulations of California state law in the USA. The packaging of the TS4000 series unit indicates the statement shown below.

Perchlorate Material - special handling may apply.
See www.dtsc.ca.gov/hazardouswaste/perchlorate/.

If exporting a product with an embedded TS4000 series unit that contains a lithium primary battery to the State of California, the above statement must be indicated on the product's packaging.

4.4.5 Notes on Transport

- The "TS-BT" replacement battery is a lithium metal battery (not contained in or packed with equipment) and classified as non-dangerous goods.
- Transportation of batteries containing lithium metal must observe the relevant transport regulations. Hakko Electronics ships products packed in accordance with transport regulations. If there is a need to transport a product after it has been unpacked or its package is opened, transport the unit in accordance with the IATA Dangerous Goods Regulations, International Maritime Dangerous Goods (IMDG) Code, and transport regulations of the countries concerned. Ask your forwarding agent for details of transport regulations.

5 Inspection and Maintenance

5.1 Inspection and Maintenance

5.2 Warranty Policy

5.1 Inspection and Maintenance

**DANGER**

Always turn off the power before conducting inspection or maintenance. Failure to do so could cause an electric shock or damage to the unit.

5.1.1 Daily Inspection

- Check that the screws on the TS4000 series unit are tightened firmly.
- Check that the connectors and terminal screws used for connection with other devices are tightened firmly.
- If the display surface or frame is dirty, wipe it with a soft cloth soaked in commercially available alcohol.
- Conduct periodical inspection once or twice a year. The number of inspections may be increased as necessary if facilities are relocated or modified, or the environment is hot, humid, or dusty.

5.1.2 Periodical Inspection

Inspect the following points periodically.

- Are the ambient temperature and humidity appropriate?
0 to +50 °C, 85 %RH or less
- Are the environmental conditions appropriate?
No excessive dust and no conductive dust
- Is there corrosive gas in the atmosphere?
- Is the source voltage in the allowable range?
24 VDC \pm 10%
- Are the TS4000 series mounting screws tightened firmly?
- Are the connectors and terminal screws used for connection with other devices tightened firmly?
- Has the coin-type lithium battery passed its replacement date?
Within about 5 years from the date of manufacture

5.2 Warranty Policy

5.2.1 Inquiries about Failure

Please direct inquiries about failure or repair to your local sales representative.

Please provide information including the MONITOUCH model, serial number, symptoms of the failure, error messages (if shown), etc.

- * See the label on the back of the unit for the model code and serial number (nine digits plus one letter of the alphabet).
The serial number is labeled as shown in the figure on the right.

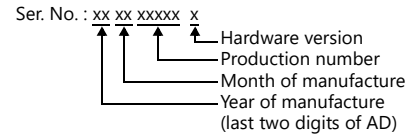

5.2.2 Warranty Period

The product is under warranty for one year after the date of purchase or delivery to the specified place.

On the assumption that the maximum stock period of the product after manufacture is 6 months, the warranty period is limited to 18 months (checked by the serial number) after manufacture.

When a warranty period is specified in the contract, however, the period in the contract takes precedence.

5.2.3 Free-of-charge Repair

If the product fails before the expiry of the warranty, it will be repaired free of charge.

However, repair of any failure resulting from the causes below will be chargeable even within the warranty period.

- Breakage of or damage to the appearance (casing or surface sheet), touch switches, LCD, or other components due to dropping, impact, or mishandling
- End of service life of the LCD or backlight
- Fusion of a printed circuit board pattern associated with connection to external devices, or fusion of a pattern in the terminal block or connector section of a printed circuit board caused by short-circuiting of an external load circuit.
- Overvoltage or different voltage applied due to wiring mistakes (power supply terminal, external communication terminal, or other terminal blocks)
- Failure caused by a lightning surge
- Failure due to the entry of conductive substances, water, solvent, particles, etc. under inappropriate environmental conditions
- Failure due to inappropriate environmental conditions (e.g. corrosive gas or high humidity)
- Failure due to vibration or impact exceeding the specified level
- Disassembly and modification by the customer or failure obviously resulting from improper handling by the customer

5.2.4 Chargeable Repair

Any failure that occurs after the expiry of the warranty or that does not satisfy the requirements for free-of-charge repair will be repaired on a chargeable basis.

 **Hakko Electronics Co., Ltd.**
www.monitouch.com

890-1, Kamikashiwano-machi, Hakusan-shi, Ishikawa,
924-0035 Japan
Tel +81-76-274-2144
E-mail support@hakko-elec.co.jp